



# ITU Competition Rules

21/02/2012 Edition

Approved by the ITU Executive Board, February 2012



The ITU Competition Rules is the master source document, found on ITU's website at [www.triathlon.org](http://www.triathlon.org). The web based document acts as the official (authorised) reference document and is maintained based on authorised amendments in accordance with recommendations by the ITU Technical Committee and accepted by the ITU Executive Board.

### **Contact**

International Triathlon Union (ITU)  
#221-998 Harbourside Drive  
North Vancouver, British Columbia  
Canada, V7P 3T2

Tel (1 604) 904 9248

Fax (1 604) 904 9249

Email: [ituhdq@triathlon.org](mailto:ituhdq@triathlon.org)

For general information about ITU visit [www.triathlon.org](http://www.triathlon.org)

## TABLE OF CONTENTS

1. INTRODUCTION:	4
2. CONDUCT OF ATHLETES:	6
3. PENALTIES:	12
4. SWIMMING CONDUCT:	15
5. CYCLING CONDUCT:	18
6. RUNNING CONDUCT:	24
7. TRANSITION AREA CONDUCT:	25
8. COMPETITION CATEGORIES:	26
9. PRIZES AND AWARDS:	27
10. EVENTS:	29
11. TECHNICAL OFFICIALS:	31
12. PROTESTS:	33
13. APPEALS:	35
14. INDOOR TRIATHLON:	38
15. LONG DISTANCE TRIATHLON:	39
16. TEAM AND RELAY CHAMPIONSHIPS:	40
17. PARATRIATHLON:	42
18. WINTER TRIATHLON:	52
19. CROSS TRIATHLON AND DUATHLON:	54
20. COMPETITION IN QUALIFYING ROUND FORMAT:	55
21. APPENDIX A: RACE DISTANCES AND AGE REQUIREMENTS:	58
22. APPENDIX B: RACE PROTEST FORM:	60
23. APPENDIX C: RACE APPEAL FORM:	62
24. APPENDIX D: DEFINITIONS:	64
25. APPENDIX E QUALIFICATION AND RANKING CRITERIA.	69
26. APPENDIX UNIFORM RULES	98
27. APPENDIX G: LINK TO PARATRIATHLON CLASSIFICATION MANUAL:	119
28. APPENDIX H: PRIZE MONEY BREAKDOWN:	120
29. APPENDIX I: ITU RELATED MULTISPORTS:	121
30. APPENDIX J: ITU EVENTS AND ITU EVENT CATEGORIES:	122
31. APPENDIX K: PENALTIES AND VIOLATIONS:	124

## **1. INTRODUCTION:**

### **1.1. Purpose:**

- a.) The International Triathlon Union (ITU) is the sole governing body, responsible for Competition Rules for Triathlon, Duathlon and its other related multisports. The complete list of sports under the jurisdiction of ITU is included as Appendix A and Appendix J;
- b.) The International Triathlon Union Technical Committee (ITU-TC) will ensure technical aspects of ITU competitions are of the highest quality;
- c.) The ITU Competition Rules specify the conduct and behaviour of athletes during ITU competitions. Where the ITU Competition Rules do not specify, the rules of FINA, UCI, IAAF, FIS, IPC swimming and IPC athletics will apply in their specific segments;
- d.) The ITU Event Organisers' Manual and its related documents set safety and logistical standards for host National Federations (NFs) and for the Local Organizing Committees (LOCs);
- e.) The ITU Technical Officials' (ITO) Programme sets the standards for certifying ITU Technical Officials;
- f.) When a rule applies only for specific competitions, this will be indicated in the rule.

### **1.2. Intention:**

- a.) The ITU Competition Rules are intended to:
  - (i) Create an atmosphere of sportsmanship, equality, and fair play;
  - (ii) Provide safety and protection;
  - (iii) Emphasise ingenuity and skill without unduly limiting the athlete's freedom of action;
  - (iv) Penalise athletes who gain an unfair advantage;
- b.) Definitions of all terms used in the ITU Competition Rules are provided in Appendix D. Any difficulty in the interpretation or application of the ITU Competition Rules should be referred to the ITU Technical Committee.

### **1.3. Language and Communication:**

- (i) The official language of ITU Events is English;
- (ii) NFs are responsible for translation services as required.

### **1.4. Modifications:**

- a.) The ITU Competition Rules will be adapted for other modern multisport competitions, which fall within ITU's jurisdiction.
- b.) An athlete must not be permitted an advantage not intended by a rule, or to conduct him/herself in a dangerous way. To implement this, every infringement related in the ITU Competition Rules has a sanction attached. Officials base their judgments on whether an advantage, not intended by the Rules, has been gained.
- c.) ITU Competition Rules will be applicable to international competitions hosted by National Federations (NFs) affiliated with ITU.

### **1.5. Exceptions:**

- a.) The ITU Competition Rules will be applicable to all events sanctioned by ITU and are to be implemented by the appointed Technical Delegate as appropriate. Where the ITU Competition Rules conflict with the laws of the jurisdiction in which the event is to be held, the ITU Competition Rules will override the laws of the jurisdiction to the

extent of the inconsistency, Athletes must be notified of the implications of these laws as early as possible and not later than prior to the start of the event. Exceptions for special circumstances in a particular event may only be gained from ITU with prior approval. A request for an exception to the ITU Competition Rules must be made in writing to the ITU Technical Committee (ITU-TC) through the NF to whom the application has been submitted or is being submitted.

#### **1.6. Specific Regulations:**

- a.) A Technical Delegate may approve the addition of specific regulations for a particular race, provided that:
  - (i) Each additional specific regulation does not conflict with another ITU Competition Rule;
  - (ii) Each additional specific regulation is made available in written form and is announced at the athletes' briefing; and
  - (iii) Each additional specific regulation and the reasons for its inclusion are advised to the ITU-TC one week before the day on which the event is to be conducted. The ITU-TC may invalidate the incorporation of an additional specific regulation only on the authority of the ITU Executive Board.

#### **1.7. Unauthorised Exceptions or Additions:**

- a.) The unauthorised exception to, or addition of, a Competition Rule will prevent an event from being sanctioned and will invalidate a sanction, which has already been granted to an event. This could result in legal complications, particularly in the case of accidents during the event and in subsequent requests for approval from NFs and/or municipal authorities to use roads and waterways. Insurance authorities have also warned that claims made under such circumstances may be considered invalid.

#### **1.8. Rule Updates:**

- a.) The ITU Competition Rules may be changed from time to time by the ITU-TC at its discretion, with the approval of the ITU Executive Board. Any such rule change(s) shall be advised in writing to affiliated NFs at least 30 days before it/they is/are to take effect. Updated ITU Competition Rules will be posted on the ITU website ([www.triathlon.org](http://www.triathlon.org)).

## **2. CONDUCT OF ATHLETES:**

### **2.1. General Conduct:**

- a.) Triathlon and ITU's other related multisports involve many athletes. Race tactics are part of the interaction between athletes. Athletes will:
  - (i) Practice good sportsmanship at all times;
  - (ii) Be responsible for their own safety and the safety of others;
  - (iii) Know, understand and follow the ITU Competition Rules, available from their NFs and on [www.triathlon.org](http://www.triathlon.org);
  - (iv) Obey traffic regulations and instructions from race officials.
  - (v) Treat other athletes, officials, volunteers, and spectators with respect and courtesy.
  - (vi) Avoid the use of abusive language.
  - (vii) Inform a Technical Official after withdrawing from the race.
  - (viii) Compete without receiving assistance other than from event personnel and officials.

### **2.2. Drug Abuse:**

- a.) Athletes will follow the ITU Anti-Doping Rules;
- b.) All athletes are responsible for familiarizing themselves with the ITU Anti-Doping Rules including medical and doping control tests, testing obligations, rights, responsibilities and procedures, penalties and appeal processes, and prohibited substances;
- c.) ITU has implemented the ITU Anti-Doping Rules and abides by rules set by the World Anti-Doping Agency (WADA) Code.

### **2.3. Health:**

- a.) Triathlons and ITU's other related multisports are strenuous. To be able to compete, athletes should be in excellent physical condition. Their health and welfare is of paramount importance. By starting in a race, the athletes declare they are in good health and are in appropriate physical condition to complete the race;
- b.) Time limits for the swim leg, bike leg and overall finish time may be established for each competition by the Technical Delegate. These limits must be published in the pre-event registration material.
- c.) ITU encourages athletes to perform periodic health evaluation (PHE) and to undergo a pre-participation evaluation (PPE) prior to engaging in competitive sport

### **2.4. Eligibility:**

- a.) All athletes must be in good standing with their National Federations. To ensure this, all the entries must be done by the NFs, not by the athletes themselves.
- b.) Athletes under suspension are not allowed to compete in any ITU event, in any competition sanctioned by ITU members, or in any competition held under the ITU Rules.
- c.) An athlete's age is determined by their age on December 31<sup>st</sup> in the year of competition
- d.) Athletes aged 14 to 16 years old are eligible to compete in the Youth category.
- e.) Athletes aged 16 to 19 years old are eligible to compete in the Junior category.

- f.) Athletes aged 18 to 23 years old are eligible to compete in the U23 category.
- g.) The different qualification criteria are published in Appendix E.
- h.) Specific Olympic qualification criteria are published in Appendix E.
- i.) Athletes may not compete within 48 hours (as determined by the start times of the first wave) in more than one related multi-sport event (see Appendix J) when one event is of standard distance or longer. An exception will be for team relay events at the defined super-sprint distances (see 15.1.a)..
- j.) Age limits: athletes must be a minimum age to compete in any ITU Event, as outlined in Appendix A. Continental Confederations may add other age limits for Continental Championships, for youth categories with super-sprint events. The age limits as outlined in Appendix A cannot be modified.
- k.) An athlete who competes in a category different from his/her age, in a distance in which is not allowed, or before the 48-hour period, will be disqualified from the events he/she took part in. Any awards, prizes and points will be removed.

## **2.5. Insurance:**

- a.) Each athlete competing in an ITU event must have personal insurance coverage, guaranteed by their NF. This insurance will cover:
  - (i) Any accident occurring before, during and after any triathlon competition.
  - (ii) Any sickness that an athlete could suffer during a trip to a triathlon competition or event.
  - (iii) The liability caused by an athlete during the competition.
  - (iv) The athlete's NF guarantees the existence of this insurance by entering an athlete in an event. LOCs or NFs organizing an event cannot force the athletes to pay for a race day fee for insurance purposes.

## **2.6. Registration:**

- a.) Entry:
  - (i) NFs will register their athletes for ITU events following their NF qualification system or other ITU approved qualification system;
  - (ii) Elite, U23 and Junior athletes qualify by following the eligibility rules outlined in 2.4 and Appendix E of the ITU Competition Rules;
  - (iii) Prior to competing in ITU Triathlon World Cups or ITU World Triathlon Series events, elite athletes must sign the ITU Athletes' Agreement, which states that any dispute arising from the ITU Rules that cannot be settled by its existing appeal procedure, shall be settled finally by the Court of Arbitration for Sport (CAS) in Lausanne, Switzerland, to the exclusion of recourse to ordinary courts. Once signed, the ITU Athletes' Agreement is valid until the end of the competition year it has been signed;
  - (iv) NFs are responsible for entering their athletes and coaches for all ITU Events using the ITU online system on [www.triathlon.org](http://www.triathlon.org);
  - (v) All age-group, Junior and U23 athletes must provide picture ID at race registration/packet pick-up prior to competition;
- b.) Pre-Race Briefings:
  - (i) Coaches' Meeting: If a coaches' meeting is scheduled, it will take place one hour before the Athletes' Briefing. The TD will conduct the Coaches Meeting'. The agenda will include all the technical details of the event as well as specific information for coaches. Coaches' accreditations will be distributed at this

meeting, or if the Coaches' Meeting is not scheduled, accreditations will be distributed at the end of the Elite/U23/Junior Athletes' Briefing;

- (ii) Age-Group Team Managers' Briefing: At World Championships, the TD will conduct the Age-Group Team Managers' and Coaches briefing. Only Age-Group Team Managers are allowed to attend. The agenda of this briefing will include all the necessary information for the event. A separate briefing will be conducted for Paratriathlon;
  - (iii) Elite/U23/Junior Briefings: At all ITU Events, the TD will conduct the Athletes' Briefing. Elite/U23/Junior athletes must be in attendance. Coaches may also attend the briefing. The following penalties apply to athletes who miss the briefing:
    - Athletes not attending the briefing, without informing the TD about their absence, will be removed from the start list;
    - Athletes entering the briefing hall after the briefing has started and athletes not attending the briefing, but who have informed the TD about their absence, will be reallocated to the last position on the pre-start line up;
    - For the World Triathlon Series or ITU Triathlon World Cup events, if an athlete misses more than two briefings in a calendar year, they will be removed from the start list for the third missed briefing and each missed briefing thereafter;
  - (iv) Athletes must register prior to entering the briefing venue;
  - (v) In the case of force majeure, the athletes' status will be referred to the Competition Jury;
  - (vi) For Triathlon World Series and ITU Triathlon World Cup events, there is one single Athletes' Briefing for female and male athletes. The briefing will be held at 18h00 local time two days prior to the first elite competition day. For all other ITU events the briefing will take place at 18.00 either one or two days before the first competition day. Alteration to this time should be announced on the ITU website 45 days in advance.
- c.) Packet Pick-Up:
- (i) All ITU events - Age Group:
    - All athletes must pick up their own race packet at the official race registration area during a designated time. Packet pick-up will be opened on two (2) separate days, starting from 3 days prior to their competition. The hours shall be from 09:00 to 19:00. If an NF is unable to make the designated registration time, they must request a different time at least 14 days in advance, in writing to ITU.
    - The race packets will contain a minimum of: five (5) official race numbers (one (1) for body, one (1) for bicycle and three (3) for helmet) and four (4) safety pins, numbered swim cap, timing chip, accreditation pass, athletes' guide, tickets for all the social functions. LOC gifts may be distributed at the same time.
  - (ii) All ITU Events - Elite, U23 and Junior Competitions:
    - All athletes will pick up their own race packet at Registration following the Athletes' Briefing.
    - The race packet will include: three (3) helmet numbers, one (1) bike number, body decals for both arms and both legs, accreditation pass, athletes' guide, tickets for all the social functions. LOC gifts may be distributed at the same time.



- d.) Race Day Check-in:
  - (i) Technical Officials will conduct the race day Elite, U23 and Junior check-in at the Athletes' Lounge and will include the following:
  - (ii) Distribution of the swim caps and timing chips.
  - (iii) Control of the athletes' uniform, which must comply with the ITU Uniform Rules. (Appendix F). Each uniform will be photographed.
  - (iv) Distribution of the race packets to the athletes who missed the briefing.

## **2.7. Uniform.**

- a.) All athletes competing in ITU events are required to wear their NF uniform conforming to the ITU Uniform Rules (see Appendix F).
- b.) Athletes must follow the following rules with respect to wearing uniforms
  - (i) Athletes must wear the uniform during the entire competition and award ceremony.
  - (ii) The uniform must cover the whole torso in the front. The back may be uncovered from the waist up.
  - (iii) Arms, below the shoulders must be uncovered. The TD may authorize this area to be covered based on the weather conditions. Wetsuits, when authorized, may cover the arms but not the hands. This paragraph doesn't apply to Winter Triathlon events.
  - (iv) A one piece uniform is preferred. If a two piece uniform is used, the space between the top and the bottom may be not visible, so the two pieces overlap. The athlete must cover the torso during the entire race.
  - (v) Zippers must be on the back and will be a maximum of 30 cm long. Front zippers are not allowed. This paragraph do not apply to Long Distance events.
  - (vi) The uniform must be worn over both shoulders for the duration of the competition.
  - (vii) Elite, U23 and Junior athletes must wear the same uniform from the start to the finish, in events of standard distance or shorter.
  - (viii) Rain jackets are allowed when the TD authorizes it. Rain jackets must be the same design and color as the uniform or transparent.
  - (ix) Long sleeves and long pants are allowed for the award ceremony.
  - (x) Failure to comply with the ITU Competition Rules related to uniform may result in an athlete having to wear a triathlon suit supplied by ITU or covering any logos on the uniform not allowed by the Rules.

## **2.8. Race numbers**

- a.) Race numbers (bib numbers) must be worn by athletes during the run segment. The race number must be visible on the front. Elite, U23 and Junior athletes in any World Championships or World Cup are exempt from this rule, except in Winter Triathlon events.
- b.) Bib numbers may be worn in the bike and wetsuit swim segments.
- c.) Bib numbers are forbidden in a non wetsuit swim segment.
- d.) Body marking:
  - (i) The LOC will provide body marking decals for the elite athletes, who will apply them prior to the event.

- (ii) Body markings are to be applied to each arm and leg, unless instructed otherwise by the ITU TD at the briefing.
- (iii) Body markings and/or decals using multiple digits will have numbers appearing one above the other, not side to side.
- (iv) For age group events, one calf of each athlete must be marked with the category and gender of the athletes (For example, the number M25 would appear on a male athlete in the 25 – 29 age category or F25 should appear on a female athlete in the same category)

## **2.9. Assignment of race numbers:**

### a.) General:

- (i) Athlete's race numbers are assigned based on previous race results in similar events.
- (ii) The elite men's and women's events will be numbered starting with number 1, except in Long Distance events.
- (iii) Number 13 will be not used.

### b.) Specific events numbering criteria:

#### (i) World Triathlon Series and Grand Final:

- First criteria: Current WTS rankings
- Second criteria: ITU Points List
- Third criteria: random

#### (ii) Triathlon U23 World Championship:

- First criteria: Current WTS rankings
- Second criteria: ITU Points List
- Third criteria: ITU U23 World Ranking
- Fourth criteria: random

#### (iii) Junior - Any event:

- First criteria: One athlete per nation randomly.
- Second criteria: Other athlete per nation randomly.
- Third criteria: Other athlete per nation randomly.
- Continue this process till the list is exhausted.

#### (iv) Triathlon World Cup events:

- First criteria: ITU Points List
- Second criteria: random

#### (v) Triathlon Continental Cup events:

- First criteria: ITU Points List
- Second criteria: Continental rankings from the same continent as the event.
- Third criteria: random

#### (vi) Triathlon Elite Continental Championships:

- First criteria: Top 10 the previous year.
- Second criteria: ITU Points List
- Third criteria: Continental rankings from the same continent of the event
- Fourth criteria: random

#### (vii) Triathlon U23 Continental Championships:

- First criteria: ITU Points List
- Second criteria: random

- (viii) Multisport – Any Elite event:
  - First criteria: ITU Related Rankings
  - Second criteria: random
- (ix) Age Group - Any event:
  - First criteria: Age group by age group
  - Second criteria: Grouped by nations in alphabetical order starting by the host nation.

## 2.10. Timing and Results:

- a.) A race will be won by the athlete who has the shortest time from the start signal to the moment when the athlete finishes the race as defined in 6.2 a) and 17.8 a)
- b.) All the athletes will be ranked according to their times.
- c.) The official results will list the athletes according to their finish time and in accordance with the ORIS standards. Time splits to be included are:
  - (i) Swim or first segment
  - (ii) Transition 1
  - (iii) Bike or second segment
  - (iv) Transition 2
  - (v) Run or third segment
  - (vi) Overall finish time
- d.) Results will include athletes who do not finish the race (DNF), those who do not start (DNS), those who are disqualified (DSQ) and any lapped athletes (LAP), listed in this order:
  - (i) Athlete's marked DNF or LAP (together in one group) are listed first, followed by DSQ and finally DNS
  - (ii) If more than one athlete is marked DNF or LAP, those who completed the most laps should be listed first; if several athletes are marked DNF or LAP on the same lap, athletes should be listed according to their times at the previous timing point with the fastest first, or by ascending start number if no times were recorded up to the point at which they retired
  - (iii) If more than one athlete is marked DNS they should be listed within the same group according to ascending start number
  - (iv) If more than one athlete is marked DSQ they should be listed within the same group according to ascending start number
  - (v) For DSQ athletes, achieved results and ranking (from previous race stages) should not be displayed
- e.) For relay events, the rules above are applicable and the total time per athlete will be shown.

### **3. PENALTIES:**

#### **3.1. General Rules:**

- a.) Failure to comply with the ITU Competition Rules may result in an athlete being verbally warned, punished with a time penalty, disqualified, suspended, or expelled;
- b.) The nature of the rule violation will determine the subsequent penalty.
- c.) A suspension or an expulsion will occur for very serious violations of either the ITU Competition Rules or the ITU Anti-Doping Rules.
- d.) Reasons for Penalty: An athlete may be issued a verbal warning, punished with a time penalty, or disqualified for failing to abide by the ITU Competition Rules. All the infringements and penalties are listed in Appendix L.
- e.) The Technical Officials are allowed to assess penalties, even if the infringement is not listed, if the Technical Official deems an unfair advantage has been gained, or if a dangerous situation has been created intentionally.

#### **3.2. Verbal Warning:**

- a.) The purpose of a verbal warning is to alert an athlete about a possible rule violation and to promote a "proactive" attitude on the part of officials.
- b.) A verbal warning may be given when:
  - (i) An athlete violates a rule unintentionally;
  - (ii) A Technical Official believes a violation is about to occur;
  - (iii) No advantage has been gained.

#### **3.3. Time Penalty:**

- a.) It is not necessary for a Technical Official to give a verbal warning prior to issuing a more serious penalty;
- b.) A time penalty is appropriate for minor infringements;
- c.) Time penalties will be served in a designated Penalty Box or in the Transition Area.
- d.) Giving a Time Penalty:
  - (i) A warning will be given at the discretion of the Technical Official. If time and conditions permit, a Technical Official will assess a Time Penalty by:
    - Sounding a whistle or horn; showing a yellow card; calling (in English) the athlete's number and saying "Time Penalty" (if appropriate). For safety reasons, a Technical Official may have to delay issuing a warning.
    - Alternatively, the athletes may be informed about the penalties by displaying the athlete's number on a panel posted at the entrance of the penalty box. It is the athlete's responsibility to check this board.
- e.) Procedure while serving a time penalty. When given a yellow card, the athlete will follow the instructions of the Technical Official.
  - (i) Time Penalty in Transition
    - The Technical Official will hold a yellow card as the penalized athlete arrives at his/her position. The athlete will be ordered to stop in his/her transition space without touching any of their equipment.
    - Once the athlete stops, the Technical Official starts to time the penalty.
    - When the penalty time is finished, the Technical Official will say "Go" and the athlete can continue with the race.

- (ii) Time Penalty at the Bike Penalty Box:
  - The athlete will be told by the Technical Official to report to the next Penalty Box and follow the instructions of the Technical Official there. It is the athlete's responsibility to report to the next penalty box on the course after receiving notification. Athlete bib numbers are not posted for a Bike Penalty Box
  - The penalized athlete will enter the Penalty Box and inform the Technical Official of their identity and number of penalties to serve. The time penalty starts when the athlete enters the Penalty Box and ends when the Technical Official says "Go", at which time the athlete may continue with the race.
- (iii) Time Penalty at the Run Penalty Box:
  - The penalized athletes' numbers will be clearly displayed on a board before the Penalty Box.
  - The penalized athlete will proceed into the Penalty Box and inform the Technical Official of their identity and number of penalties to serve. The time penalty starts when the athlete enters the Penalty Box and ends when the Technical Official says "go", at which time the athlete may continue with the race.
  - The penalized athlete's number will be removed from the board once the penalty is served.
  - A penalized athlete may serve their penalty on any lap of the run.
  - For relay events, the penalty may be served by the any member of the team, who has not yet completed their portion of the event.
  - Penalties must be posted on the board before the athlete completes the first half of the run. Postings after this time are invalid.

### 3.4. Disqualification:

- a.) General:
  - (i) A disqualification is a penalty appropriate for severe rule violations, such as but not limited to, repeated bike draft infringements, and/or dangerous or unsportsmanlike conduct.
- b.) Assessment:
  - (i) If time and conditions permit, a Technical Official will assess a disqualification by:
    - Sounding a whistle or horn;
    - Showing a red card;
    - Calling (in English) the athlete's number and saying "Disqualified";
    - For safety reasons, a Technical Official may have to delay issuing a disqualification.
  - (ii) Alternatively, the athletes may be informed about the penalties by displaying the athlete's number on the white board posted at the post finish area.
- c.) Procedure after Disqualification:
  - (i) An athlete may finish the race if a Technical Official issues a disqualification.

### 3.5. Suspension:

- a.) General:
  - (i) A suspension is a penalty appropriate for fraudulent or very severe rule violation, such as but not limited to repeated dangerous or unsportsmanlike conduct;

- (ii) A suspended athlete will not take part in ITU competitions or competitions sanctioned by NFs affiliated with ITU during a suspension period.
- b.) Assessment:
  - (i) The Race Referee will inform the athlete or NF, verbally or if not possible by posting the notice on the notice board, about the submission of a report to the ITU EB, which may result in a suspension.
  - (ii) The Race Referee will submit a report to the ITU EB including all the details of the action, and the reasons to recommend the athlete for suspension. This report will be submitted to the ITU Secretary General within one week of the competition.
- c.) Suspensions will be assessed by the ITU EB for periods of three (3) months to four (4) years, depending on the violation
- d.) Suspension due to Drug Abuse: If the suspension is for drug abuse, the athlete will not be able to compete in any other sport whose federation is recognised by ITU, IOC or SportAccord and vice versa.
- e.) Reasons for Suspension:
  - (i) A list of infringements, which may result in a suspension, is described in Appendix K;
- f.) Disciplinary Notice:
  - (i) When an athlete is suspended, the ITU President will notify the concerned NF, in writing, within 30 days;
  - (ii) All suspensions will be announced in the ITU newsletter and communicated to the IOC and SportAccord.

### **3.6. Expulsion:**

- a.) General:
  - (i) Athletes who have been expelled will not participate in ITU competitions or competitions sanctioned by NFs affiliated with ITU for life.
- b.) Reasons for Expulsion:
  - (i) An athlete will be expelled for life for repeated rule violations that incur suspension as the penalty.
  - (ii) Expulsion due to Drug Abuse: If the expulsion is for drug abuse, the athlete will not be able to compete in any other sport whose federation is recognised by ITU, IOC or SportAccord and vice versa.
- c.) Disciplinary Notice:
  - (i) When an athlete is expelled, the ITU President will notify the concerned NF, in writing, within 30 days;
  - (ii) expulsions will be announced in the ITU newsletter and communicated to the IOC and SportAccord..

### **3.7. Right of Appeal:**

- a.) Athletes punished with a penalty have the right to appeal.

### **3.8. Reinstatement:**

- a.) After suspension, an athlete must apply to the ITU Executive Board for reinstatement.

#### 4. SWIMMING CONDUCT:

##### 4.1. General Rules:

- a.) Athletes may use any stroke to propel themselves through the water. They may also tread water or float. Athletes are allowed to push off the ground at the beginning and the end of every swim lap.
- b.) Athletes must follow the prescribed swim course.
- c.) Athletes may stand on the bottom or rest by holding an inanimate object, such as a buoy or stationary boat.
- d.) In an emergency, an athlete should raise an arm overhead and call for assistance. Once official assistance is rendered, the athlete must retire from the competition.

##### 4.2. Wetsuit Use:

- a.) Wetsuit use is governed by the following tables:

###### Elite, U23 and Junior athletes

Swim Length	Forbidden Above	Mandatory Below	Maximum Stay in Water
300m	20° C	14° C	10 min.
750m	20° C	14° C	20 min.
1500m	20° C	14° C	30 min.
3000m	22° C	16° C	1 h 15 min.
4000m	22° C	16° C	1 h 45 min.

###### Age-Group athletes:

Swim Length	Forbidden Above:	Mandatory Below:	Maximum Stay in Water
750m	22° C	14° C	30 min.
1500m	22° C	14° C	1 h 10 min.
3000m	23° C	16° C	1 h 40 min.
4000m	24° C	16° C	2 h 15 min.

##### 4.3. Modifications:

- a.) The swim distance can be shortened or even cancelled according to this table:

Original swim distance	Temperature of water				
	16.9°C – 16.0°C	15.9°C – 15.0°C	14.9°C – 14.0°C	13.9°C – 13.0°C	Below 13.0°C
750 m	750 m	750 m	750 m	750 m	Cancel
1500 m	1500 m	1500 m	1500 m	750 m	Cancel
3000 m	3000 m	3000 m	1500 m	Cancel	Cancel
4000 m	4000 m	3000 m	1500 m	Cancel	Cancel

*\* Note: The temperatures above are not always the water temperature used in the final decision. If the water temperature is lower than 20°C and the air temperature is lower than the water temperature, then the adjusted value is to decrease the measured water temperature by 0,5°C every 1.0°C of difference between the air and water temperatures.*

(*)		Air temperature							
		15°C	14°C	13°C	12°C	11°C	10°C	9°C	8°C
Water temperature	20°C	17.5°	17°C	16.5°C	16°C	15.5°C	15°C	14.5°C	14°C
	19°C	17.0°C	16.5°C	16°C	15.5°C	15°C	14.5°C	14°C	13.5°C
	18°C	16.5°C	16°C	15.5°C	15°C	14.5°C	14°C	13.5°C	13°C
	17°C	16°C	15.5°C	15°C	14.5°C	14°C	13.5°C	13°C	Cancel
	16°C	15.5°C	15°C	14.5°C	14°C	13.5°C	13°C	Cancel	Cancel
	15°C	15°C	14.5°C	14°C	13.5°C	13°C	Cancel	Cancel	Cancel
	14°C	14°C	14°C	13.5°C	13°C	Cancel	Cancel	Cancel	Cancel

- b.) If other weather conditions dictate, i.e., high winds, heavy rain, etc. the Technical and Medical Delegates may adapt limits of the swim length or adapt provisions about the wetsuit use. The final decision will be made one hour before the start and will be clearly communicated to the athletes by the Technical Delegate.
- c.) For aquathlon events, if the water temperature is below 22° C the event will be modified to a Swim-Run event.
- d.) Water temperature must be taken one (1) hour prior to the start of the event on race day. It must be taken at the middle of the course and in two other areas on the swim course, at a depth of 60 cm. The lowest measured temperature will be considered as the official water temperature.

#### 4.4. Starting Position Selection: (Elite/U23/Junior athletes):

- a.) Prior to the start of competition, athletes are lined up in the order of their start numbers, unless their positions have been reallocated after the Athletes' Briefing.
- b.) The athletes go directly to their selected numbered position upon entering the pontoon and stay in that position behind the pre-start line until the start procedure. A selected position cannot be changed by any athlete during the Starting Position Selection process. An athlete cannot occupy more than one start position.
- c.) Start-line Technical Officials note each athlete's race number and the starting position selected.
- d.) Starting Position Selection ends when every athlete is in a start position.

#### 4.5. Start Procedure: (Elite/U23/Junior Athletes):

- a.) After all athletes are in position (confirmed and noted by the Start-line Technical Officials) "On your marks!" is announced and the athletes step forward to the start-line (without stepping on it).
- b.) Any time after the announcement, the start signal will be given, by blasting a horn and the athletes will move forward towards the first turn buoy (triathlon).
- c.) The following Technical Officials are involved in the start procedure with equipments:
  - (i) Two Start Technical Officials are standing beside each other in the middle of the start area behind the athletes;
    - The first Start Technical Official is responsible for announcing "On your marks";
    - The second Start Technical Official is responsible for giving the start signal;



- (ii) Two False Start Technical Officials stand on both sides of the start area to have a clear view of the start;
  - An air horn is used to provide a false start signal (several short horn blasts);
  - A photo/video camera is used to identify early starters;
- d.) False Start: In case of a false start (several athletes move forward before the start horn) the athletes must come back to their previously selected position. This will be controlled by the Start-line Technical Officials and the start procedure will begin again.
- e.) Early Start: In the case of an early start of a few athletes, the race can continue, the False Start Technical Officials can decide that the start is valid. The early starters will receive a 15 seconds time penalty in Transition 1. In case of relay events, the time penalty has to be served by the first athlete of the team.
- f.) The same procedure will apply for the start of any other Multisport event starting with running with adaptations from swim start to run start.

#### **4.6. Equipment**

- a.) Legal Equipment:
  - (i) All athletes must wear the official event swim cap during the swim segment.
  - (ii) Swim caps are provided by ITU or the LOC.
  - (iii) If an athlete chooses to wear two caps, the official cap must be on the outside.
  - (iv) No sponsor logos are allowed on the swim cap other than as prescribed by the ITU / LOC.
  - (v) Athletes may not alter the swim caps in any manner.
  - (vi) Failure to wear the official swim cap, or altering the official swim cap, may result in a penalty up to and including disqualification.
  - (vii) Only certified wetsuits are allowed when wetsuit use is permitted.
  - (viii) Athletes must wear their ITU approved uniform for non-wetsuit swims. If athletes choose to wear a second suit, it must be worn underneath the official uniform and cannot be removed during the entire competition.
- b.) Illegal Equipment:
  - (i) Athletes must not use:
    - Artificial propulsion devices;
    - Flotation devices;
    - Gloves or socks;
    - Wetsuits with thickness exceeding 5mm;
    - Wetsuit bottoms only;
    - Wetsuits when they are forbidden;
    - Non-certified swimsuits: Wetsuits and swimsuits not in compliance with the ITU Uniform Rules;
    - When the use of wetsuits is forbidden, clothing covering any part of the arms below the shoulders and clothing covering any part of the leg below the knees.

## **5. CYCLING CONDUCT:**

### **5.1. General Rules:**

- a.) An athlete is not permitted to:
  - (i) Block other athletes;
  - (ii) Cycle with a bare torso;
  - (iii) Make forward progress without being in possession of the bike.
- b.) Dangerous Behaviour
  - (i) Athletes must obey the specific traffic regulations for the event, unless a Technical Official advises otherwise.

### **5.2. Equipment:**

- a.) In general, UCI rules (as 1st January of the current year) will apply during competition and also during familiarization sessions and official training:
  - (i) UCI road race rules for draft-legal triathlon and duathlon races.
  - (ii) UCI time trial rules for draft-illegal triathlon and duathlon races.
  - (iii) UCI MTB rules for winter triathlon, cross triathlon and cross duathlon races.
- b.) Bikes must have the following characteristics:
  - (i) For draft-legal races, the frame of the bike shall be of a traditional pattern, i.e., built around a main triangle of three straight or tapered tubular elements, which may be round, oval, flattened, teardrop shaped or otherwise in cross-section.
  - (ii) The frame will be no more than two (2) metres long, and fifty (50) centimetres wide for draft-legal competitions. For all other competitions, two (2) metres long and seventy-five (75) centimetres wide will be permitted.
  - (iii) The frame will measure at least 24 centimetres from the ground to the centre of the chain wheel axle.
  - (iv) There will be a vertical line touching the front-most point of the saddle which will be no more than 5 centimetres in front of, and no more than 15 centimetres behind, a vertical line passing through the centre of the chain wheel axle, and an athlete must not have the capability of adjusting the saddle beyond these lines during competition.
  - (v) There will be no less than 54 centimetres and no more than 65 centimetres between a vertical line passing through the centre of the chain wheel axle and a vertical line through the centre of the front wheel axle.
  - (vi) Fairings are prohibited.
  - (vii) Non-traditional or unusual bikes or equipment shall be illegal unless prior approval has been granted from the Technical Delegate, prior to the start of the competition.
  - (viii) Only logos of bicycle related products may appear on the athlete's bicycle.
  - (ix) Logos may not interfere with, or hinder the placement of, the bicycle race number on the bicycle frame.
  - (x) Bike race number stickers, provided by ITU or the LOC, must be placed on the bike as instructed, without any alteration.

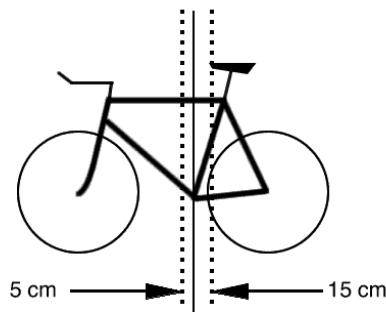
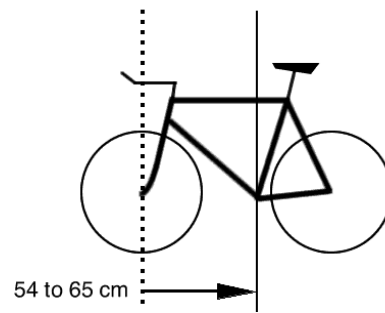
**Diagram 6 Saddle Fore-Aft Position****Diagram 7 Front to Centre Distance**

## c.) Wheels:

- (i) No wheel may contain any mechanisms, which are capable of accelerating it.
- (ii) Tyres must be well glued, headsets tight and wheels true.
- (iii) There must be a brake on each wheel.
- (iv) Wheels can be replaced only at official Wheel Stations, where provided.
- (v) Officials at the Wheel Station will give the proper wheel to the athlete. The athlete is responsible for replacing the wheel in the forks. Wheels designated specifically for other athletes or teams can not be used.
- (vi) For draft-legal competitions, wheels must have the following characteristics:
  - A diameter between 70 cm maximum and 55 cm minimum, including the tyre.
  - Both wheels should be of equal dimension.
  - Wheels shall have at least 12 spokes.
  - Spokes can be round, flattened or oval, provided their width does not exceed 10 mm.
  - Wheels not complying with the requirements above are allowed to be used if they are included in the UCI approved wheels list.
- (vii) For draft-illegal competitions, covers are allowed on the rear wheel. However, this provision may be changed by the Technical Delegate in the interest of safety, i.e. high-winds.

## d.) Handlebars:

- (i) For draft-legal races the following handlebar rules will apply:
  - Only traditional drop handlebars are permitted. The handlebars must be plugged;
  - Certified clip-on handlebars will be permitted if they are not longer than the foremost line of the brake levers.
  - No space is permitted between the left and right hand side of the clip-on bar at its forward most point
  - Forward facing handlebars must have a solid standard factory bridge joining both sides of the handlebar at its forward most point.
  - Brake levers must be mounted on the handlebar, not on the clip-on and may not face forward.
  - No forward facing gear shifters are allowed on the end of the clip-on handlebars.
  - Clip-on handlebars must be mounted parallel to the ground.
  - Water bottles and water bottle holders may not be mounted onto the handlebars or clip-on.

- (ii) For draft-illegal races, the following rules on handlebars apply:
  - Only handlebars and clip-on bars not extending beyond the leading edge of the front wheel will be permitted. Clip-on bars in two pieces do not need to be bridged. All tube ends have to be plugged.
- e.) Helmets
  - (i) Helmets must be approved by a national accredited testing authority recognised by an NF affiliated with ITU;
  - (ii) An alteration to any part of the helmet, including the chin strap, or the omission of any part of the helmet, including an outer cloth cover, is prohibited;
  - (iii) The helmet must be securely fastened at all times when the athlete is in possession of the bike, which means from the time they remove their bike from the rack at the start of the bike leg, until after they have placed their bike on the rack at the finish of the bike leg;
  - (iv) If an athlete moves the bike off the course for any reason, the athlete may not unfasten or remove the helmet until after he/she has moved outside the boundary of the bike course route and has dismounted the bike; and he/she must fasten the helmet securely on the head before returning onto the bike course or before remounting the bike.
  - (v) Helmets must comply with the ITU Uniform Rules.
- f.) Platform Pedals
  - (i) Platform pedals are allowed, provided a quick-release mechanism is fitted to ensure the release of the feet in case of a fall.
- g.) Illegal Equipment
  - (i) Illegal equipment includes, but is not limited to:
    - Headphone(s) or headset(s);
    - Glass containers;
    - Mobile phone(s) or any other electronic listening communication device.
    - Bike or parts of the bike not complying with these rules.
    - Uniform not complying with the ITU Uniform Rules.
  - h.) Any equipment or devices carried during the bike segment or added to the bike is subject to approval by the Race Referee before the race. Non approved devices are forbidden and may result in the disqualification of the athlete.
  - i.) For cameras and videocameras, in addition to requiring approval from the Race Referee, all the images and footage taken will be copied by ITU. The use of those images for commercial purpose is subject to approval by ITU EB.

### **5.3. Bike Check:**

- a.) A bike check will take place upon Check-in to the Transition Area before the competition. Technical Officials will check that bikes comply with the ITU Competition Rules.
- b.) Athletes may request approval from the Race Referee during the Athletes' Briefing to allow them to make modifications, if necessary, to comply with the rules.

### **5.4. Overlapping:**

- a.) Elite, U23 and Junior athletes who have been lapped during the bike segment will be withdrawn from the race. This provision can be modified by the TD, following the procedure outlined in 1.5.

## 5.5. Drafting:

### a.) General Guidelines

- (i) There are two kinds of competitions, depending of the allowance of drafting:
  - Draft-legal races
  - Draft-illegal races
- (ii) The races will be draft-legal or illegal according to this table:

	Junior	U23	Elite	Age-Group	Paratriathlon
<b>TRIATHLON</b>					
Team Relay	Legal	legal	legal		
Sprint Distance	Legal	legal	legal	illegal	illegal
Standard Distance		legal	legal	illegal	illegal
Long Distance Triathlon (O2, O3)			illegal	illegal	illegal
<b>DUATHLON</b>					
Team Relay	Legal	legal	legal		
Sprint Distance	Legal	legal	legal	illegal	illegal
Standard Distance		legal	legal	illegal	illegal
Long Distance			illegal	illegal	illegal
<b>AQUATHLON</b>					
<b>WINTER TRIATHLON</b> (all distances)	Legal				
<b>CROSS TRIATHLON AND DUATHLON</b> (all distances)	Legal				

### b.) Draft-Illegal Races:

- (i) Drafting from another athlete or motor vehicle is forbidden. Athletes must reject attempts by others to draft;
- (ii) An athlete is entitled to any position on the course, provided they get to that position first and without contacting others. When taking a position, an athlete must allow reasonable space for others to make normal movements without making contact. Adequate space must be available before passing;
- (iii) An athlete who approaches from any position to take advantage of the draft, bears responsibility for avoiding the draft;
- (iv) To draft is to enter the bicycle or vehicle drafting zone:
  - Bicycle draft zone: the bicycle draft zone will be a rectangle. The width will always be 3 metres wide. The center of the leading 3 metre edge will be measured from the leading edge of the front wheel. The length of the rectangle will depend on the distance of the race: for Long distance events the length will measure 12 metres; for Standard distance events or shorter, the length will measure 10 metres.
  - An athlete may enter the draft zone of another athlete, but must be seen to be progressing through that zone. A maximum of 20 seconds will be allowed to pass through the zone of another athlete.

- Vehicle draft zone: The vehicle draft zone will be a rectangle thirty-five (35) metres long by five (5) metres wide which surrounds every vehicle on the bike segment. The front edge of the vehicle will define the center of the leading 5 metre edge of the rectangle.
- (v) Entry into the bicycle drafting zone: An athlete may enter a bike draft zone in the following circumstances:
- If the athlete enters the draft zone, and progresses through it within 20 seconds in the overtaking manoeuvre;
  - For safety reasons;
  - 100 metres before and after an aid station or transition area;
  - At an acute turn;
  - If the Technical Delegate excludes a section of the course because of narrow lanes, construction, detours, or for other safety reasons.
- (vi) Overtaking:
- An athlete is passed when another athlete's front wheel is ahead of theirs;
  - Once overtaken, an athlete must move out of the draft zone of the leading athlete within 5 seconds.
  - Athletes must keep to the side of the course and not create a blocking incident. Blocking is where an athlete who is behind cannot pass due to the leading athlete being poorly placed on the course.
- (vii) See the diagrams below for events where left hand side road rules apply.

### Diagram 1 Distance of Drafting Zone for ALL Competitors

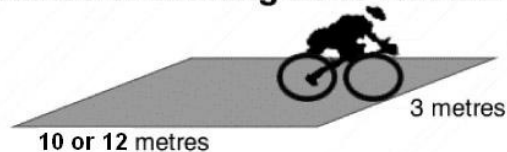

### Diagram 2 Drafting

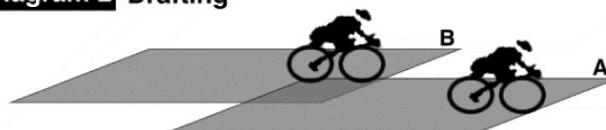

**A** has overtaken **B** and **B** is now drafting the lead cyclist **A**. **B** must drop out of **A**'s draft zone before attempting to repass **A**. **A** must move to the Left Hand Side of the road when safe otherwise **A** can be called for blocking. **B** can only overtake **A** on **A**'s Right Hand Side.

### Diagram 3 Blocking

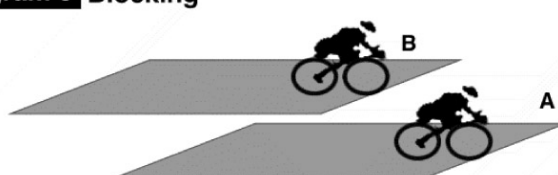

**A** and **B** are maintaining adequate separation between each other, even though they are abreast to one another. **B** is not drafting **A** in this instance. **A** however, is now in a **BLOCKING** position. If **A** remains out to the Right Hand Side, **A** will receive a blocking penalty.

**Diagram 4 Drafting and Not Drafting**



**A** and **B** are maintaining adequate separation. **C** is not attempting to pass **B**. **C** is drafting **B**. **A** and **B** are not drafting.

**Diagram 5 Vehicle Draft Zone**

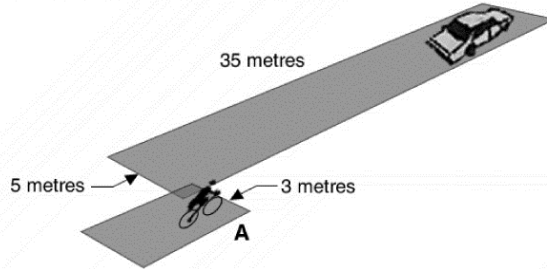

**A** is travelling at the same speed as the vehicle. **A** is drafting. **A** must move to the Left Hand Side of the road otherwise **A** can also be called for blocking.

### 5.6. Penalties for Drafting:

- a.) It is forbidden to draft in a race declared as draft-illegal.
- b.) Technical Officials will notify the athletes who draft they are subject to a time penalty sanction. This notification must be clear and unambiguous
- c.) The athlete sanctioned has to stop in the next Penalty Box and must stay there for a specific time depending on the race distance. 1 minute for sprint distance, 2 minutes for standard distance and 5 minutes for long distance.
- d.) It is the athlete's responsibility to stop in the next Penalty Box. Failing to stop will result in a disqualification.
- e.) A second drafting offence will lead to a disqualification in standard distance events or shorter.
- f.) The third drafting offence will lead to disqualification for Long Distance events.

## **6. RUNNING CONDUCT:**

### **6.1. General Rules:**

- a.) The athletes will:
  - (i) Run or walk;
  - (ii) Not crawl;
  - (iii) Not run with a bare torso;
  - (iv) Not run without shoes or run barefoot on any part of the course;
  - (v) Not run with a bike helmet on;
  - (vi) Not use posts, trees or other fixed elements to assist manouvering curves;
  - (vii) Not be accompanied by team members, team managers or other pacemakers on the course.

### **6.2. Finish Definition:**

- a.) An athlete will be judged as "finished," the moment any part of the torso, reaches the perpendicular line extending from the leading edge of the finish line.

### **6.3. Safety Guidelines:**

- a.) The responsibility of remaining on the course rests with the athlete. Any athlete, who appears to Technical or Medical Officials as presenting a danger to themselves or others, may be removed from the competition.

### **6.4. Illegal Equipment:**

- a.) Headphone(s) and headset(s), mobile phones or any other electronic listening communication device;
- b.) Glass containers;
- c.) Uniform not complying with the ITU Uniform Rules.



## 7. TRANSITION AREA CONDUCT:

### 7.1. General Rules:

- a.) All athletes must have their helmet securely fastened from the time they remove their bike from the rack at the start of the bike leg, until after they have placed their bike on the rack at the finish of the bike leg;
- b.) Athletes must use only their designated bike rack and must rack their bike;
  - (i) For a traditional bike rack, the bike must be racked as follows:
    - For the first transition: in an upright position with the front of the saddle hooked over the horizontal bar so the front wheel is pointing to the middle of the transition lane.
    - For the second transition: with at least one side of the handlebar or the seatpost within 0,5m of the rack number or name plate.
  - (ii) In case of an individual bike rack, the bike must be racked in the first transition by the rear wheel and in the second transition by the front wheel.
- c.) Athletes must place within 0,5 m of the bin all equipment to be used at a later stage in the event. If a bin is not provided, the 0,5 m will be measured from the rack number or name plate. The bin, if provided, must be within 0,5 m from the rack number or name plate. All equipment already used must be deposited in the bin. An equipment piece is considered deposited in the bin when one part of the equipment is inside the bin. Only equipment to be used during the competition can be left in transition. All other belongings and equipment are to be removed before race start.
- d.) Bike shoes, glasses, helmet, and other bike equipment can be placed on the bike.
- e.) Athletes must not impede the progress of other athletes in the Transition Area;
- f.) Athletes must not interfere with another athlete's equipment in the Transition Area;
- g.) Cycling is not permitted inside the Transition Area: Athletes must mount their bicycles after the mount line by having one complete foot contact with the ground after the mount line. Athletes must dismount their bicycles before the dismount line by having one complete foot contact with the ground before the dismount line. While in the transition area (before the mount line and after the dismount line) the bike can be pushed only by the athlete's hands. Mount and dismount lines are parts of the transition area.
- h.) Nudity or indecent exposure is forbidden;
- i.) Athletes can not stop in the flow zones of the Transition Area;
- j.) Marking positions in the Transition Area is not allowed. Marks will be removed and the athletes will not be notified.

## 8. COMPETITION CATEGORIES:

### 8.1. World Championships.

- a.) ITU may organize World Championships in the distances and categories shown in this chart:

	Elite	U23	Junior	Age-Group	Paratriathlon
<b>TRIATHLON</b>					
Team Relay	yes				
Sprint Distance	yes	yes	yes	yes	yes
Standard Distance	yes	yes		yes	yes
Long Distance (O2, O3)	yes			yes	yes
<b>DUATHLON</b>					
Team Relay	yes		yes		
Sprint Distance	yes	yes	yes	yes	yes
Standard Distance	yes	yes		yes	yes
Long Distance	yes			yes	yes
<b>AQUATHLON</b>					
Standard Distance	yes	yes	yes	yes	yes
Long Distance	yes			yes	yes
<b>WINTER TRIATHLON</b>					
Team Relay	yes		yes		
Sprint Distance			yes	yes	
Standard Distance	yes	yes			
<b>CROSS TRIATHLON AND DUATHLON</b>					
Team Relay	yes		yes		
Sprint Distance			yes		
Standard Distance	yes	yes		yes	yes

- b.) NFs and Continental Confederations should include each of these categories in their National and Continental Championships.

## 9. PRIZES AND AWARDS:

### 9.1. Prize Money:

a.) General Rules:

- (i) Prize money for the ITU events shall be distributed equally between men and women in both amount and depth, according to the ITU Prize Money Percentage Breakdown, as outlined in Appendix H.

### 9.2. Primes:

a.) Primes may be offered at ITU events. Primes are payable to the athletes as follows:

- (i) Be in first position through the prime line;
- (ii) Finish the competition;
- (iii) There is no limit to the number of primes an athlete can win in a race;
- (iv) If the prime is not collected by an athlete due to not finishing, the prime remains with ITU to be used at its discretion;
- (v) The amount of the primes will be announced at the Athletes' Briefing of each competition and will be distributed equally in amount to men and women.

### 9.3. Awards:

- a.) Athletes or team members who place 1st, 2nd or 3rd at any ITU event will be awarded an official ITU medal (gold, silver, bronze);
- b.) In addition, teams may receive a trophy for 1st, 2nd and 3rd positions.

### 9.4. Prizes, Points and Awards in combined events:

- a.) In case of events which take place together, the awards, prize money and points will be distributed as follows:

<b>Events taking place together:</b>	<b>Awards (medals) to:</b>	<b>Prize money to:</b>	<b>Points to:</b>
Elite and U23	-Awards for Elite -Awards for U23	Overall	Overall
Elite, U23 and Junior	-Awards for Elite -Awards for U23 -Awards for Junior	Overall	Overall
U23 and Junior	-Awards for U23 -Awards for Junior	n/a	Overall
All	-Awards per categories	Elite	Overall
Triathlon Continental Championships with athletes from other continents	-Award for the athletes from the continent	All	Athletes from the continent
Multisport Continental Championships with athletes from other continents	-Award for the athletes from the continent	All	Overall
Continental Cups	-Overall	Overall	ITU points: overall Continental points: Athletes from the continent

- b.) Athletes from other continents can participate in Continental Championships provided that the race is not full with the athletes from the host continent. In this case, points and medals are going to athletes from the host continent, but prize money is distributed to the athletes in the overall results. The exceptions to this paragraph are the Duathlon and Long Distance Triathlon Continental Championships that are part of the World Series as well: in this case points are distributed to the overall results.

## 10. EVENTS:

### 10.1. Swim:

- a.) To ensure the safety of the athletes, there are limits on the quantity of athletes starting at the same time.
- (i) All elite/U23/JN triathlon events in standard and sprint distance, except the World Triathlon Series: 75 athletes is the maximum number of athletes.
  - (ii) World Triathlon Series Events, except the Grand Final: 65 athletes is the maximum number of athletes
  - (iii) World Triathlon Series Grand Final: 75 athletes is the maximum number of athletes
  - (iv) Paratriathlon: 100 athletes is the maximum number of athlete.
- b.) Water quality
- (i) A sample of a mixture of the water collected from three different locations on the swim course will be analyzed and the results will determine if the swim can take place. The swim will be allowed if the following values are below the level of tolerance in the difference types of water.
    - Sea and transition water:
      - PH between 6 and 9
      - Entero-cocci not more than 100 per 100 ml (ufc/100ml)
      - Escherichiacoli E. Coli not more than 250 per 100 ml (ufc/100ml)
    - Inland water:
      - PH between 6 and 9
      - Entero-cocci not more than 200 per 100 ml (ufc/100ml)
      - Escherichiacoli E. Coli not more than 500 per 100 ml (ufc/100ml)
      - The presence of Blue-Green Algal blooms/scum (cyanobacteria) not more than 100.000 cells/ml

### 10.2. Transition:

- a.) The TD will determine the position of the mount and dismount lines. Both lines will be considered as part of the Transition Area.

### 10.3. Support team:

- a.) NF Quota: Every NF has a support team quota according to these charts.
- (i) . Elite events

Athletes	1 to 3	4 to 6	7 or more
Coaches	2	3	4

- (ii) U23 events (U23 not mixed with other categories)

Athletes	1 to 6	7 or more
Coaches	2	3

- (iii) Junior events

Athletes	1 to 6	7 or more
Coaches	2	3

(iv) Paratriathlon events

Athletes	1 to 3	4 to 6	7 or more
Coaches	2	3	4

(v) Age group events

Athletes	1 to 50	51 to 100	101 to 150	More than 151
Coaches	2	4	6	8

(vi) Delegation support

Athletes	1 to 50	51 to 100	101 to 150	More than 151
Bike mechanic	1	2	3	3
Medical	1	1	1	1
NF Representatives	2	4	6	8

- b.) All the personnel registered as part of the support team will receive an accreditation with access according to their role.
- c.) NFs are responsible for entering their support personnel in the ITU on line entry system. ITU will approve the support personnel according to the quota seven days prior to the event. No additions will be admitted after this deadline.

## 11. TECHNICAL OFFICIALS:

### 11.1. General:

- a.) The duties of the Technical Officials are to conduct the Competition in accordance with the ITU Competition Rules.

### 11.2. ITU Technical Officials:

- a.) The officials at all ITU races are:
  - (i) The ITU Technical Delegate (TD) ensures all aspects of the ITU Competition Rules and Operations Manuals are fulfilled;
  - (ii) The Assistant Technical Delegate (ATD) assists the TD with his/her duties;
  - (iii) The Referee checks the certification of the Technical Officials and makes final judgments on rule violations;
  - (iv) The Chief Race Official (CRO) assigns and monitors the work of all Technical Officials;
  - (v) Technical Officials are assigned to Registration, Start, Finish, Transition Area(s), Swim, Bike, Run, Wheel Stations, Prime Lines, Aid Stations, Technology, Penalty Boxes, Lap Counter, Protocol, Race Control Office and Vehicle Control. An adequate number of Technical Officials will be assigned to each area and will be responsible for the enforcement of ITU Competition Rules within their assigned jurisdiction;
  - (vi) The Competition Jury is appointed by the Technical Delegate;
  - (vii) The ITU Medical Delegate, appointed by the ITU Medical Committee, is responsible for all medical and anti-doping issues on behalf of ITU.

### 11.3. Competition Jury:

- a.) ITU Technical Delegate will appoint the members of the Competition Jury as follows:
  - (i) For Olympic Games and World Triathlon Series Grand Final the Competition Jury consists of five persons being selected from:
    - The Technical Delegate, who chairs the Competition Jury;
    - A member of the ITU Executive Board;
    - A representative of the host NF;
    - A representative from ITU Technical Committee;
    - A representative from the ITU Medical Committee.
  - (ii) For all the other ITU events, the Competition Jury consists of three persons being selected from:
    - The Technical Delegate, who chairs the Competition Jury;
    - A member of the ITU Executive Board or any Committees or Commissions, or if none are present, a member of the Continental Confederation's Executive Board or any Committees or Commission, or if none are present, a representative from the host NF;
    - A representative from the host NF.

- b.) Duties of the Competition Jury:
- (i) The Competition Jury rules on all appeals and all protests;
  - (ii) The Competition Jury has the authority to modify the competition results as a consequence of its decision on the appeal or protest;
  - (iii) The Competition Jury must be available starting before the Athletes' Briefing until after the end of competition;
  - (iv) The Competition Jury chair is responsible for filing a written statement on all appeals and decisions reached.
- c.) Competition Jury meetings schedule:
- (i) Competition Jury will meet, at minimum:
    - After the race briefing;
    - One hour before the start of the event;
    - After the last finisher.
  - (ii) Additionally, in the Age-Group events, the Jury will meet, at minimum:
    - After the first finisher;
    - After the finish of the first half of the field.
- d.) Competition Jury Integrity:
- (i) The Competition Jury observes the following principles:
    - Give equal weight to the evidence and testimony provided by all;
    - Recognize that honest testimony can vary and be in conflict as a result of personal observation or recollection;
    - Keep an open mind until all evidence has been submitted;
    - Recognise an athlete is innocent until the alleged violation has been established to the complete satisfaction of the Competition Jury.
  - (ii) Conflict of interest:
    - The chair of the Competition Jury decides if any member has a conflict of interest.
    - In case of a conflict of interest, the chair of the Competition Jury can replace the member who has the conflict of interest at his/her discretion.
    - The chair of the Competition Jury is deemed not to have a conflict of interest.

#### **11.4. Technology Tools:**

- a.) ITU Officials may use any kind of electric, electronic, magnetic, or other technological support to acquire data or evidence on rule infractions.

#### **11.5. Volunteer Certification:**

- a.) All volunteers, who are assigned to areas of responsibility on the Field of Play (FOP), must be educated to ITU's minimum standard. Education kits obtained from ITU will cover key areas of FOP responsibility.



## **12. PROTESTS:**

### **12.1. General:**

- a.) A protest is against the conduct of an athlete, Technical Official, or the conditions of the competition. An athlete or an NF designate may file a protest with the Referee provided the protest has not been previously observed by the Technical Officials and ruled upon by the Referee.
- b.) Where ITU Competition Rules do not cover the incident, FINA, UCI, IAAF, FIS, IPC swimming and IPC athletics Rules will apply.

### **12.2. Protests Concerning Eligibility:**

- a.) Protests concerning the eligibility of an athlete shall be made to the Referee before the Athletes' Briefing. The Competition Jury will decide on this in a meeting scheduled immediately after the Athletes' Briefing.

### **12.3. Protests Concerning the Course:**

- a.) Protests concerning the safety of the course or its variance to the regulations must be made to the Referee no later than twenty-four (24) hours before the start of the race.

### **12.4. Protests Concerning the Race:**

- a.) An athlete, who protests against another athlete or official, must do so to the Referee within fifteen (15) minutes of his/her finish time. However, the intention to write a protest has to be announced to the Referee within five (5) minutes of his/her finish time. After this deadline, only protests following this process will be admitted.

### **12.5. Protests Concerning Equipment:**

- a.) Protests concerning an athlete's equipment, which infringes on the conditions set out in the ITU Rules, must be delivered to the Referee fifteen (15) minutes after his/her finish time. However, the intention to write a protest has to be announced to the Referee within five (5) minutes of his/her finish time. After this deadline, only protests following this process will be admitted.

### **12.6. Protests Concerning Timing and Results:**

- a.) Protests concerning mistakes in timing and results (time errors, athletes' ranking) may be delivered in writing by the athlete or the NF to the ITU TD within thirty (30) days after the competition.

### **12.7. Contents of a Protest:**

- a.) The protest related to 12.2, 12.3, 12.4 and 12.5 must be accompanied by a deposit of \$50 USD, or its equivalent, and will be refunded if the protest is successful. If the protest is denied, there will be no refund and the money will be retained by ITU. Protest forms may be obtained from the Referee. A sample of the protest form is included in Appendix B.
  - (i) Information to be included:
    - The alleged rule violated;
    - The location and approximate time of the alleged violation;
    - Persons involved in the alleged violation;
    - A statement, including a diagram of the alleged violation, if possible;
    - The names of witnesses who observed the alleged violation.

## 12.8. Protest Procedures:

- a.) The following procedure will be followed in the event of a protest:
  - (i) Protests will be filed with the Referee, signed by the protester, within the time limits specified above;
  - (ii) The protester and the accused and/or their national coach or representative must be present. If the protester does not attend, the protest hearing may be postponed or cancelled. The Competition Jury will determine if absence from the hearing is valid;
  - (iii) Failure of any party to attend the hearing may justify the Competition Jury in making a decision without them;
  - (iv) A representative for either the protester or the accused may be designated to appear if approved by the Chair of the Competition Jury;
  - (v) The hearing will not be open to the public;
  - (vi) The Competition Jury Chair will read the protest;
  - (vii) The protester and the accused will be given adequate time to give their accounts of the incident;
  - (viii) Witnesses (two each) may speak for three (3) minutes each;
  - (ix) The Competition Jury will hear the evidence and render a decision, by simple majority;
  - (x) The decision will be posted immediately and delivered in writing to the parties upon request.

## 13. APPEALS:

### 13.1. Appeal Jurisdiction:

- a.) An appeal is a request for a review of a decision made by the Referee (Level 1), the Competition Jury (Level 2) or the ITU EB (Level 3). A sample of the Appeal Form is available in Appendix C.
- b.) Where ITU Competition Rules do not cover the incident, FINA, UCI, IAAF, FIS, IPC swimming and IPC athletics Rules will apply.

### 13.2. Levels of Appeal:

- a.) The following procedure will be followed in the event of a Level 1 Appeal:
  - (i) A Representative of an NF or an athlete may appeal the decision of the Referee to the Competition Jury. The appropriate appeal form can be obtained from the Referee.
  - (ii) Appeals will be filed in writing to the Referee, signed by the appellant and will be accompanied by a fee of \$50 USD or equivalent. It will be refunded if the appeal is successful. If the appeal is denied, there will be no refund and the money will be retained by ITU.
  - (iii) The time for an athlete or official team representative to file an appeal is no later than fifteen (15) minutes after his or her finishing time or the posting of the infraction, whichever is later. However, the intention to write an appeal must be announced to the Referee within five (5) minutes of his/her finishing time or posting of the infraction. After this deadline, only protests following this process will be admitted. For team competitions, this time limit is related to the final team time.
  - (iv) An appeal will contain:
    - Competition name, location, date;
    - Appellant's name, address, phone, fax, email;
    - Witness(es) name(s);
    - Alleged decision appealed;
    - Facts of the violation;
    - Rationale/summary of appeal.
  - (v) The appellant and the accused and/or their national representative must be present. If the appellant does not attend, the appeals hearing may be postponed or cancelled. The Competition Jury will determine if absence from the hearing is valid;
  - (vi) Failure of any party to attend the hearing may justify the Competition Jury in making a decision without them;
  - (vii) A representative for either the appellant or the accused may be designated to appear if approved by the Chair of the Competition Jury;
  - (viii) The hearing will not be open to the public;
  - (ix) The Competition Jury Chair will read the appeal;
  - (x) The appellant and the accused will be given adequate time to give their accounts of the incident;
  - (xi) Witnesses (two each) may speak for three (3) minutes each;

- (xii) The Competition Jury will hear the evidence and render a decision, by simple majority;
  - (xiii) The decision will be posted immediately and delivered in writing to the parties upon request.
- b.) The following procedure will be followed in the event of a Level 2 Appeal:
- (i) Appeals will be filled in writing to the ITU Secretary General, signed by the appellant, within the time limit specified above.
  - (ii) The Secretary General will communicate the appeal to all parties involved within 4 days
  - (iii) EB members who were part of the Competition Jury will be excluded from the process.
  - (iv) The ITU EB will nominate a panel of 3 persons from among its members, within seven days after receiving the appeal.
  - (v) One or more members of the panel will call, within ten days from its nomination, for different hearings, which may be done by phone or videoconference, to these parties:
    - The appellant,
    - The accused
    - The TD, if appropriate
    - The Competition Jury, if appropriate
    - Other parties at the Panel's discretion.
  - (vi) Failure of any party to attend the hearing may justify the Panel to write a proposal of decision without their evidence.
  - (vii) The hearings will be one to one between the Panel and the referred party.
  - (viii) The hearing will be driven by the Panel at its own discretion.
  - (ix) The Panel is permitted to analyze and consider any other document, video, record or evidence relevant to the case.
  - (x) The Panel will write a proposal of decision to the EB, within ten days after the last hearing.
  - (xi) The proposal will be communicated, together with all the evidence considered by the Panel, to any party directly involved in the process.
  - (xii) Any party subject to be sanctioned will have the right to defend itself by presenting its arguments, evidences and comments on the proposal, within seven days after receiving the proposal from the Panel.
  - (xiii) The EB will decide on the Panel's proposal, within ten days after receipt from the Panel. The documents from the parties will be considered also by the EB.
  - (xiv) The decision will be communicated in writing to all the parties immediately after the EB decision process is concluded.
- c.) Level 3: The decision of the ITU Executive Board may be appealed, as a final and last resort, to the Court of Arbitration for Sport (CAS) in Lausanne, Switzerland, to the exclusion of any recourse to ordinary courts. Any decision taken by the said court (CAS) shall be without appeal and shall be binding on the parties concerned.

# **ITU COMPETITION RULES: SPECIFIC DISCIPLINE COMPETITION RULES**

2012 Edition



## **14. INDOOR TRIATHLON:**

### **14.1. Definition:**

- a.) Indoor triathlon consists of a triathlon, which takes place in a closed space such as a sports pavillion, which has a swimming pool, a cycling track and a running track.

### **14.2. Swim:**

- a.) Two athletes are allowed per lane of 2.5 metres wide.

### **14.3. Transition Area:**

- a.) Following the swim there will be a ten (10) second "neutralized" time period that is compulsory for all athletes. The purpose of this period is to sponge excess water off athletes. Water on the track makes it very slippery and dangerous for all athletes. Not complying with this rule will result in disqualification.

### **14.4. Bike Segment:**

- a.) The lapped athletes will be not removed from the race;
- b.) Athletes can draft from others who are on a different lap.

## **15. LONG DISTANCE TRIATHLON:**

### **15.1. Outside Assistance:**

- a.) Medical assistance and food and liquid are permitted at LOC aid stations or at coaches' stations. All other outside assistance is prohibited.

### **15.2. Medical Guidelines:**

- a.) Specific Medical Guidelines, including "hot weather" guidelines and medical evacuation plans will be developed by the Race Medical Director in conjunction with the ITU Medical Delegate.

### **15.3. Distances:**

- a.) The course should have demanding hills and challenging technical aspects. A 5% tolerance margin will be accepted for the distance of the bike course, provided it has been approved by the Technical Delegate.

### **15.4. Penalties:**

- a.) A 5-minute penalty will be imposed for violation of the drafting rule, which must be served in the next penalty box.
- b.) If an athlete receives three drafting penalties, he/she will be disqualified.

### **15.5. Coaches Stations:**

- a.) Coaches will have a designated space available on the bike and run segments in order to supply athletes with their own food and beverages.

### **15.6. Transition Area:**

- a.) In the Transition Area, Technical Officials may assist athletes by receiving and placing their bikes and handing out their equipment. This service must be equal for all athletes.

## 16. TEAM AND RELAY CHAMPIONSHIPS:

### 16.1. Types of Events:

- a.) ITU may organise Team Events in the distances and categories shown in this chart (all distances are in kilometres with the exception of the swims, which are in metres):

	Type of competition	Distance
Triathlon	3 x 4 x Mixed	3x (250 + 6.6 + 1.6) 4x (250 to 300 + 5 to 8 + 1.5 to 2)
Triathlon LD	Adding 3 best times	O2, O3
Duathlon	3 x 4 x Mixed	3x (2 + 8 + 1) 4x (2 + 8 + 1)
Duathlon LD	Adding 3 best times	
Winter	3 x 4 x Mixed	3x (2 to 3 + 4 to 5 + 3 to 4) 4x (2 to 3 + 4 to 5 + 3 to 4)
Cross Triathlon	3 x 4 x Mixed	3x (200 + 4 to 5 + 1.2 to 1.6) 4x (200 + 4 to 5 + 1.2 to 1.6)
Cross Duathlon	3 x 4 x Mixed	3x (1.2 to 1.6 + 4 to 5 + 0.6 to 0.8) 4x (1.2 to 1.6 + 4 to 5 + 0.6 to 0.8)
Corporate Triathlon	Corporate	3x (250 + 6.6 + 1.6) 1x1500 + 1x40 + 1x10

### 16.2. Continental Championships and National Federation Events:

- a.) Continental Confederations and National Federations should include each of these team competitions in their championships.

### 16.3. Definitions:

- a.) **Mixed relay:** A team is composed of 4 athletes: 2 men and 2 women, who will compete in the following order: woman, man, woman, man. Each of them will cover a complete triathlon/duathlon/winter triathlon. The total time for the team is from the start of the 1st team member to the finish of the 4<sup>th</sup> athlete. Time is continuous and the watch does not stop between athletes.
- b.) **3x relay:** A team is composed of 3 athletes of same gender. Each of them will cover a triathlon/duathlon/winter triathlon/cross triathlon/cross duathlon. The total time for the team is from the start of the 1st team member to the finish of the 3<sup>rd</sup> athlete. Time is continuous and the watch does not stop between athletes.
- c.) **Corporate:** A team is composed of 3 athletes regardless of gender. The first athlete will cover the swim segment, the second one the bike segment and the third one the run segment. The total time for the team is from the start of the 1st team member to the finish of the 3<sup>rd</sup> athlete. Time is continuous and the watch does not stop between athletes.
- d.) **Team competition based on the individual results:** The total team time is the addition of the 3 best times of the athletes from the same nation and gender. In case of a tie, the time of the third team member will determine the team result.

### 16.4. Results:

- a.) Each NF can enter more than one team, but only the team with the best finishing position will be listed in the results.

### 16.5. Eligibility:

- a.) The general eligibility rules apply. The minimum age is 16 years.



**16.6. Uniform:**

- a.) The ITU Uniform Rules apply. All members of a team must wear the same country uniform.

**16.7. Team Relay Briefing:**

- a.) Team relay briefing. A briefing for the coaches will be conducted the day before the event.

**16.8. Team Composition:**

- a.) The team coach will nominate the team members at the team relay briefing.
- b.) One hour before the race start, the coach can communicate a different team composition to the TD, otherwise the team composition communicated at the team relay briefing will remain.

**16.9. Race Day Check-In:**

- a.) All the team members must check in together.

**16.10. Relay Exchange:**

- a.) The relay exchange from one team member to another will take place inside the exchange zone, which is 15 metres long.
- b.) The exchange is completed by the in-coming athlete, using their hand to contact the body of the out-going athlete within the relay zone.
- c.) If contact occurs outside the exchange zone, both athletes must return to the exchange zone and complete the exchange properly.
- d.) If the exchange is not completed inside the exchange zone, the team will be disqualified.
- e.) Prior to the relay exchange, the athletes will wait in a pre-relay exchange area until the Technical Official tells them to enter the exchange zone.

**16.11. Penalty Box:**

- a.) Time penalties are to be served at the penalty box can be served by any team member currently competing on the field of play.

**16.12. Finish:**

- a.) Only the last team member is allowed to cross the finish line.

## 17. PARATRIATHLON:

### 17.1. General:

- a.) Paratriathlon, as per the ITU Constitution, is governed by the ITU Competition Rules. This section contains the rules which affect only paratriathlon.
  - (i) All World Triathlon Series events and World Cup Series events, Duathlon World Championships and Triathlon and Duathlon Continental Championship events hosting an Age-Group competition, must host a paratriathlon race as part of the mass participation event. The Paratriathlon World Championship and the Paratriathlon Continental Championships championship must be hosted as a separate event from the Age Group competitions. In all other events, the technical delegate and the LOC will decide on the status of the paratriathlon competition;
  - (ii) It is mandatory for all paratriathlon competitors, who use catheters or other urinary diversion devices, to prevent spillage by using a catheter bag at all times. This includes during training, competition and classification.

### 17.2. Paratriathlon Categories:

- a.) ITU Paratriathlon Categories shall be established based on physical disabilities. Please refer to the ITU Paratriathlon Classification Rules and Regulations for eligible impairments. Medical evidence shall be required for classification.
- b.) The six (6) categories are as follows:
  - (i) TRI 1 - Wheelchair user: Includes Paraplegic, Quadriplegic, Polio, Double Leg Amputee and disabilities that prevent the safe use of a conventional bicycle. Must use handcycle (as described in section 16.11) on bike course and racing wheelchair (as described in section 16.13) on the run;
  - (ii) TRI 2 - Severe leg impairment, including above knee amputees. Must ride bicycle and run with above knee prosthesis or run using crutches;
  - (iii) TRI 3 - Les Autres: Includes athletes with Multiple Sclerosis, Muscular Dystrophy, Cerebral Palsy, double leg amputee or paralysis in multiple limbs. Must ride a bicycle or tricycle and run. May use braces or prosthesis;
  - (iv) TRI 4 - Arm impairment: Includes paralysis, above elbow amputees and below elbow amputees, or impairment in both upper limbs. Must ride a bike. May use prosthesis, brace or sling on the bike and/or run;
  - (v) TRI 5 - Moderate leg impairment: Includes below-knee amputees. Must ride a bicycle and may run with prosthesis;
  - (vi) TRI 6 - Visual Impairment: Includes a visual acuity of less than 6/60 vision or visual field less than 40 degrees with best corrective vision. One guide of the same gender is mandatory throughout the race.
- c.) All paratriathletes are allowed to compete in triathlon, duathlon and aquathlon events. Only paratriathletes from categories TRI2, TRI3, TRI4, TRI5 and TRI6 are allowed to compete in winter triathlon, cross triathlon and cross duathlon events;
- d.) In general, all the categories start together in a paratriathlon event. In case of an event with more than 100 entries, the TD should create two start waves in consultation with the LOC in which the athletes should be grouped together per category and per gender;
- e.) In a Duathlon event, a paratriathlon race should be organized in two wave starts with a difference of at least one (1) minute. TRI1 athletes should start in the first wave and the rest of the athletes in the second wave;

### 17.3. Classification:

- a.) Paratriathlon Classification Rules and Regulations can be found in Appendix G.
- b.) All Paratriathletes competing at an ITU sanctioned competition must have an international paratriathlon classification to ensure they meet the minimal eligibility criteria for competition and are assigned an appropriate profile and category. Paratriathletes requiring classification will need to:
  - (i) be available to attend an International Classification appointment with an ITU designated Classification Panel prior to the competition;
  - (ii) provide, at time of classification, the "Certificate of Medical Diagnosis" or "Medical Diagnostic Form for Athletes with a Visual Impairment" signed by the appropriate medical personnel, a passport sized photo and any other relevant medical documentation.
- b.) Paratriathletes competing at an ITU event, where classification is not available, will be informed through their National Federation to submit specific medical documentation to ITU, no later than 4 weeks before competition, so that a temporary classification can be assigned to them.

### 17.4. Paratriathletes' briefing:

- a.) A compulsory briefing of paratriathletes will be held before all ITU events and will be conducted by the ITU TD. Paratriathlon coaches may also attend the briefing.
  - (i) Paratriathletes not attending the briefing without informing the TD of their absence, may be removed from the start list.
  - (ii) Paratriathletes must notify registration official(s) of their presence upon entering the briefing room.
- b.) All guides and handlers must be registered at the briefing.
- c.) All athletes will pick up their own race packet following the briefing. The race packet will include:
  - (i) TRI1: red swim cap, 3 race number stickers for the helmet, 1 race number sticker for the handcycle, 1 race number sticker for the race wheelchair, 1 race number sticker for the daily wheelchair, 1 race bib number for the athlete and 2 race bib numbers for the handlers;
  - (ii) TRI4: yellow swim cap, 3 race number stickers for the helmet, 1 race number sticker for the bike, 3 race number stickers for the prosthesis , 1 race bib number for the athlete and 1 race bib number for the handler;
  - (iii) TRI2, TRI3 and TRI5; yellow or green swim cap, 3 race number stickers for the helmet, 1 race number sticker for the bike, 3 race number stickers for the prosthesis/aiding devices, 1 race bib number for the athlete and 1 race bib number for the handler;
  - (iv) TRI6: 1 green swim cap for the athlete and 1 white swim cap for the guide, 6 race number stickers for the helmets, 1 race number sticker for the bike, 1 race bib number for the athlete and 1 race bib number for the guide with the word "GUIDE" written on it.
  - (v)

### 17.5. Paratriathlon Handlers

- a.) Securing qualified aides (handlers) shall be the responsibility of the paratriathlete, and all such handlers shall be identified to and receive credentials from the ITU technical officials at the Paratriathlon Briefing.

- b.) Handlers are to be allotted as follows:
  - (i) One (1) handler for categories TRI 2, TRI 3, TRI 4, and TRI 5;
  - (ii) Up to two (2) handlers for category TRI 1;
  - (iii) No handlers for category TRI 6 (Guides may act as the handler for this category).
- c.) Handlers are specifically allowed to assist paratriathletes by:
  - (i) Helping with prosthetic devices or other assistive devices;
  - (ii) Lifting paratriathletes in and out of handcycles and wheelchairs;
  - (iii) Removing wetsuits or clothing;
  - (iv) Repairing bikes and helping other equipment at the paratriathletes; transition zone area or at the official wheel station. TRI 6 guides can help to repair the bike along the whole bike course, without receiving external help.
- d.) All handlers shall be subject to the ITU Competition Rules in addition to further regulations deemed appropriate or necessary by the Race Referee.
- e.) Any action taken by a handler, which propels the paratriathletes forward may result in a disqualification.

#### **17.6. Paratriathlon Registration Process**

- a.) Briefing registration:
  - (i) Paratriathletes have to sign the attendance list in order to enter the briefing room. At this stage, they must communicate to the registration officials whether they will have their own handler, or if they need an LOC handler;
  - (ii) Paratriathletes must attend the briefing with their handler;
  - (iii) Immediately after the briefing, they will collect their race packet and their handler will collect the handlers' t-shirt, as provided by the LOC.
- b.) Paratriathletes' lounge check in
  - (i) Paratriathletes and handlers must check in together;
  - (ii) Handlers need to present themselves with the race bib number and the official handler's t-shirt;
  - (iii) If a paratriathletes is present without his/her handler/s, he/she has to wait until the handler/s arrive. If the paratriathletes wishes to register on his/her own, then the handler will not have access to the Field of Play;
  - (iv) Once a handler has been registered, they can only be replaced in exceptional circumstances and only by the TD.
  - (v) Timing chips will be delivered during this process;
  - (vi) Equipment (prosthesis, crutches, etc) for the pre-transition area (must have a race number on it) and will be checked at the paratriathletes' lounge.

#### **17.7. Pre-Transition Area conduct:**

- a.) If a pre-Transition area exists, competitors in categories TRI1, TRI2, TRI3 and TRI5 may remove their wetsuits before accessing wheelchairs or collecting other ambulatory/prosthetic devices in this area. Only the TRI 1 handlers are allowed in this area.
- b.) Paratriathletes' handlers racing in the TRI 1 category are allowed to assist their assigned paratriathlete in this area but can not propel nor push TRI1 paratriathletes forward.

- c.) The wheelchairs provided by the TRI 1 paratriathletes for this area must have functional brakes.
- d.) The closest available area to the swim exit area will always be used to line up the TRI 1 wheelchairs, according to their race number.
- e.) There should be a dedicated space in the pre-transition area area, to set up and display all prosthetic devices/crutches for paratriathletes from categories TRI 2, TRI 3 and TRI 5 (if required). Two TOs will coordinate the distribution of these equipment devices to the athletes as they exit the water and receive notification of the race number from the TO situated at the water exit. All of the equipment will be lined up in numerical order.

#### **17.8. Transition Area Conduct:**

- a.) No guide dogs will be allowed in the transition area at any time.
- b.) The LOC shall provide a minimum of 12 swim exit handlers at swim exit area, who will be responsible for assisting the paratriathletes from the swim exit to the pre-transition area. The final number of swim exit handlers shall be determined by the ITU Technical Delegate. Only these persons will be allowed to enter this area. Their training should be supervised by the ITU Technical Delegate.
- c.) During the swim exit, the competitors will receive assistance from the swim exit handlers according to their swim cap colours, as follows:
  - (i) Red: Paratriathlete needs to be lifted from the swim exit to the wetsuit removal area;
  - (ii) Yellow: Paratriathlete needs to be supported to walk/run from the swim exit to the wetsuit removal area;
  - (iii) Green or white: Paratriathlete does not need any assistance at the swim exit. White caps will be used for the guides.
- d.) Bicycles, tandems, handcycles or tricycles are not allowed from the swim exit to the transition area.
- e.) All equipment shall remain within each paratriathlete's assigned space in the transition zone. The only exception to this rule is when a "pre-transition area" exists. (This pre-transition area shall be set-up in coordination with the Technical Delegate).
- f.) All TRI6 positions in the transition zone must be the closest to the mount line (women and men), followed by the rest of the categories TRI 5, TRI 4, TRI 3, TRI 2, and TRI 1. TRI 1 paratriathletes are allowed to ride the handcycle inside the transition area.

#### **17.9. Paratriathlon Swimming Conduct / Equipment:**

- a.) For safety reasons, categories will be presented during the paratriathlete presentation at race start in the following order: TRI6, TRI5, TRI4, TRI3, TRI2, TRI1. For safety reasons, TRI1 competitors should always enter the water after all other paratriathletes are in place.
- b.) The swim start shall be an "in-water" start.
- c.) If the swim portion consists of multiple laps, paratriathletes will not be required to exit the water between laps
- d.) Artificial propulsive devices including (but not limited to) fins, paddles, or floating devices of any kind are not allowed. All prosthetic and/or orthoses devices are considered propulsion devices. Use of any such devices will result in disqualification. Any objects, screws or prosthetic devices that may be potentially harmful can be banned by the ITU Technical Delegate prior to the competition.

- e.) Wetsuit use is determined by the chart below:

Swim length	Wetsuits mandatory below	Maximum stay in water
750 m	18 °C	45 mins
1500 m	18 °C	1 h 10 mins
3000 m	18 °C	1 h 40 mins
4000 m	18 °C	2h 15 mins

If any competitor has not completed the swim course within this time limit and is more than 100 metres short of the finish, they shall be removed immediately from the water.

- f.) Wetsuits will not be permitted when the water temperature is 28° Celsius or above.
- g.) The swim portion may be cancelled if the official water temperature is lower than 16° C. (Official water temperature is calculated as indicated in the chart below)
- (i) If the water temperature is lower than 20° Celsius and the air temperature is lower than the water temperature, the adjusted value is the measured temperature decreased by 0.5°C every 1.0°C of difference between the air and water temperatures. This adjusted values is the official water temperature.

		Air temperature					
		16°C	15°C	14°C	13°C	12°C	11°C
Water temperature	20°C	18°C	17.5°C	17°C	16.5°C	16°C	Cancel
	19°C	17.5°C	17°C	16.5°C	16°C	Cancel	Cancel
	18°C	17°C	16.5°C	16°C	Cancel	Cancel	Cancel
	17°C	16.5°C	16°C	Cancel	Cancel	Cancel	Cancel
	16°C	16°C	Cancel	Cancel	Cancel	Cancel	Cancel

#### 17.10. Paratriathlon Cycling Conduct / Equipment:

- a.) Paratriathlon competitions are non-drafting events.
- b.) In paratriathlon competitions, the term “bike” used herein shall include bicycles, tandems, tricycles or handcycles.
- c.) All bikes shall be propelled by human force. Arms or legs can be used to propel the cycle, but not both. Any violation shall result in disqualification.
- d.) Bike specifications for paratriathlon competitions are outlined in the ITU Competition Rules section 5.2.
- e.) The specifications of a tricycle are as follows:
- (i) The tricycle is a vehicle with three (3) wheels of equal diameter. The front wheel, or wheels shall be steerable. The rear wheel(s) shall be driven through a system comprising of pedals and a chain;
- (ii) Recumbent tricycles are not allowed;
- (iii) All tricycles shall conform to the International Cycling Union (UCI) construction and measurements for a bicycle, including the bottom bracket, seat tube and saddle position (excluding the rear triangle);

- (iv) Wheels of the tricycle may vary in diameter between 70 cm maximum and 55 cm minimum including the tyre, using conventional cycle components. Modified hub attachments may be used if necessary. The width of tricycle double wheels may vary between 85 cm maximum and 60 cm minimum, measured at the centre of each tyre as it touches the ground;
  - (v) If a tricycle's two-wheel rear axle does not have a differential, only one wheel must be driven, due to the different speeds of the wheels in turns;
  - (vi) A tricycle shall not measure more than 200 cm in length and 95 cm in width overall;
  - (vii) The tricycle's top tube may slope down rearwards, to an inclination parallel with the down tube to facilitate easy mounting by the rider;
  - (viii) The two wheels of a tricycle may be offset by a maximum of 10 cm either side of a centreline, which passes through the single wheel and the frame top tube;
  - (ix) A tricycle shall be fitted with a safety bar to prevent the front wheel of a following tricycle from entering the space between the rear wheels. The safety bar must be fixed to the tricycle so that there is no risk of the bar moving during competition. The distance from the ground to the centre of the safety bar should be the same as the distance between the ground and the middle of the hub when the tyres are inflated to the pressure used in competition.
- f.) Protective shields, fairings or other devices, which have the effect of reducing resistance, are not allowed.
  - g.) Artificial handgrips and prosthetics are allowed but may not be fixed to the bike. Rigid prosthetic adaptations that are mounted or fixed to any part of the bike are not allowed.
  - h.) Except for handcycles (TRI 1), a rider's position shall be supported solely by the pedals, the saddle and the handlebars.
  - i.) Paratriathletes in the TRI 2 category not wearing a prosthesis may use a support for the thigh only if there is no fixation of the thigh to the bicycle. (For example, the support may be a half tube attached to the cycle, with a closed base and maximum of 10 cm closed side at the base, but no "thigh fixing devices" are allowed).
  - j.) Bikes must have two independent braking systems. .
  - k.) Handcycles and tricycles must have two braking systems, one at the front and one at the back. The braking system on the double wheels must be dynamic and act on both wheels.
  - l.) All requests for impairment adaptations to any bike or handcycle must be submitted in writing for ITU approval at least one (1) month before any event, with a clear explanation and pictures. If the adaptation is approved, a certificate will be sent by ITU to the applicant within 10 working days
  - m.) The ITU technical officials shall not be liable for any consequences deriving from the choice of equipment and/or any adaptations used by paratriathlete, nor for any defects it may have, or its non-compliance.
  - n.) No guide dogs will be allowed on the bike course at any time.
  - o.) No bike course shall have a maximum gradient of over 12% at the steepest section.

#### **17.11. Paratriathlon TRI 1 Cycling Conduct:**

- a.) Paratriathletes must use a handcycle in a recumbent position.
- b.) Specifications of a recumbent position handcycle are as follows:

- (i) A handcycle shall be an arm powered, three-wheeled vehicle with an open frame of tubular construction, which conforms to the general principles of the International Cycling Union's (UCI) construction for bicycles (except that the chassis frame tubes need not be straight). For the seat or backrest construction, the maximum frame tube diameter may not exceed the maximum defined by the general principles of UCI;
- (ii) The single wheel may be of a different diameter to the double wheels. The front wheel or wheels shall be steerable; the single wheel, either front or rear, shall be driven through a system comprising handgrips and a chain. The handcycle shall be propelled solely through a chainset and conventional cycle drive train, of crank arms, chainwheels, chain and gears, with handgrips replacing foot pedals. It shall be propelled by the hands, arms and upper body only;
- (iii) The athlete must have clear vision. As such, the horizontal of the paratriathlete's eye line must be above the crank housing/crank set, when (s)he is sitting with his/her hands on the handlebars facing forward at full extent, the tip of his/her shoulder blades in contact with the backrest and his/her head in contact with the headrest, when applicable. From this position, conforming measurements are calculated as follows: (#1) The distance from the ground to the centre of the paratriathlete's eyes and (#2) the distance from the ground to the centre of the crank housing (crank set). Measurement #1) must be equal or greater than measurement #2 All handcycles must have a mirror fixed either to the helmet of the rider or at some point on the front of the bike to ensure rear-view vision is possible;
- (iv) Adjustments to handcycle may not be made during the race;
- (v) Wheels of the handcycle may vary in diameter between a 406 mm minimum and a 622 mm maximum. Modified hub attachments may be used if necessary. The width of handcycle double wheels may vary between 55 cm minimum and 70 cm maximum, measured at the centre of each tyre where the tyres touch the ground;
- (vi) Disk wheels are not permitted for handcycles;
- (vii) A handcycle shall not measure more than 250 cm in length or 70 cm in width;
- (viii) The shifting device can either be within the extremities of the handlebars, or on the side of the paratriathlete's body;
- (ix) The largest chain ring shall have a guard securely fitted to protect the paratriathlete. This protection shall be made of solid material that is sufficiently robust and covers the chain ring fully over half of its circumference (180°) on the side facing the rider;
- (x) Maximum frame tube dimension shall be 80 mm, irrespective of tube material, or profile. Any fillets, or ribs, inserted at joints between tubes, shall be for strengthening purposes only. Non-functional, aerodynamic devices are not permitted for competition;
- (xi) A quick release body harness is permitted;
- (xii) It is mandatory that a handcycle with two rear wheels should be fitted with a safety bar to prevent the front wheel of a following handcycle from entering the space between the rear wheels. A safety bar must not exceed the width of each rear wheel tyre and all tube ends must be closed or plugged. The safety bar must be fitted 15 mm ( + / - 2 mm) behind the wheels. It must be around tube (at least 18 mm in diameter) and made of adequately solid material to resist impact without bending or breaking. The distance between the ground and the bar axis must be 280 mm (+/- 10 mm). The structure and assembly of



the safety bar must guarantee that normal bumps, which may be experienced during a race, don't affect the safe functioning of the bar (see diagram).

**This rule will come into effect from October 15th 2012.**

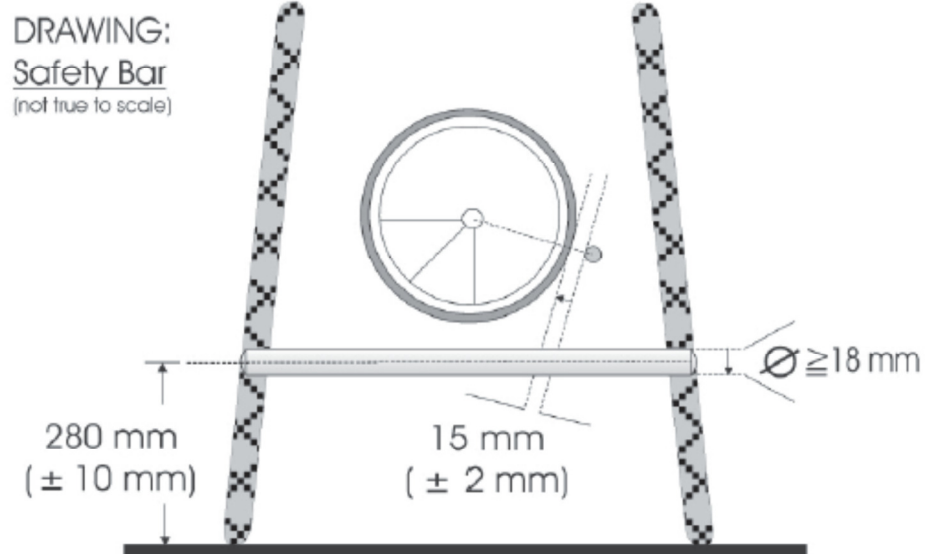

#### 17.12. Paratriathlon TRI 1 Running Conduct/ Equipment:

- a.) TRI 1 competitors perform the run portion in a "racing wheelchair" and are governed by all ITU Competition Rules with regards to safety.
- b.) The specifications of a "racing wheelchair" (hereafter referred to as "the chair") are as follows:
  - (i) The chair shall have two large wheels and one small wheel;
  - (ii) No part of the body of the chair may extend forwards beyond the hub of the front wheel and be wider than the inside of the hubs of the two rear wheels. The maximum height from the ground of the main body of the chair shall be 50 cm;
  - (iii) The maximum diameter of the large wheel, including the inflated tyre, shall not exceed 70 cm. The maximum diameter of the small wheel, including the inflated tyre, shall not exceed 50 cm;
  - (iv) Only one plain, round, hand rim is allowed for each large wheel. No mechanical gears or levers that propel the chair shall be allowed;
  - (v) Only hand operated, mechanical steering devices will be allowed;
  - (vi) Competitors must be able to turn the front wheel manually to the left and right;
  - (vii) No part of the chair may protrude behind the vertical plane of the back edge of the rear tyres;
  - (viii) It will be the paratriathlete's responsibility to ensure the wheelchair conforms to all the above rules and no event shall be delayed while adjustments are made to the chair;
  - (ix) Paratriathlete must ensure no part of their lower limbs can fall to the ground during the event;
  - (x) Paratriathlete shall wear an approved bike helmet at all times while seated in the chair.

- b.) Propulsion by any other method except the paratriathlete pushing on the wheels or push-rims will result disqualification. A paratriathlete attempting to overtake another paratriathlete carries the responsibility of ensuring full clearance of the chair being overtaken before cutting across. The paratriathlete being overtaken has the responsibility not to obstruct or impede the passing paratriathlete once the front wheel(s) of the passing chair are in sight.
- c.) TRI 1 athletes will be judged as finished, the moment any part of the torso, reaches the perpendicular line extending from the leading edge of the finish line.

**17.13. Paratriathlon TRI 2 to TRI 6 Running Conduct / Equipment:**

- a.) Competitors may use prosthetics, canes or crutches to ambulate the course.
- b.) The only acceptable footwear on the run course (aside from prosthetics) are running shoes.
- c.) No guide dogs are allowed on the run course at any time.

**17.14. Paratriathlon TRI 6 Conduct:**

- a.) The following additional rules apply to all visually impaired (TRI 6) paratriathlete and their guides:
  - (i) All paratriathletes must have a guide of the same gender. Both athlete and guide will hold a license from the same National Federation.
  - (ii) Each paratriathletes is allowed a maximum of one (1) guide during each race.
  - (iii) All paratriathletes must be tethered during the swim. The tether may be used around the waist, leg or foot.
  - (iv) All paratriathletes and guides must use a tandem bicycle. The specifications of the tandem bicycle are as follows:
    - A tandem is a vehicle for two riders, with two wheels of equal diameter, which conforms to the general principles of UCI construction for bicycles. The front wheel shall be steerable by the front rider, known as the pilot. Both riders shall face forward in the traditional cycling position and the rear wheel shall be driven by both cyclists through a system comprising pedals and chains;
    - The tandem top tube and any additional strengthening tubes, may slope to suit the morphological sizes of the riders.
  - (v) A paratriathlete must respect a waiting period of twelve (12) months after his/her last elite ITU event before competing as a guide.
  - (vi) All guides must comply with minimum age requirements as per the ITU Competition Rules Appendix A.
  - (vii) In the event of an injury or illness, and upon presentation of a medical certificate, a guide may be replaced up to 24 hours before the official start of the competition. No changes will be allowed after this deadline.
  - (viii) All TRI 6 paratriathletes must be tethered during the run. They may receive verbal instructions only from their guide.
  - (ix) All TRI 6 paratriathletes shall use approved "black out glasses" during the entire run portion (beginning at their assigned space in the transition area.

- (x) Paddleboards, kayaks, etc. (on the swim portion) or bicycles, motor bicycles, etc., (on the run portion) or any other mechanical means of transport by guides are not allowed.
- (xi) At no time may a guide lead or pace the paratriathlete nor propel them forward by pulling or pushing.
- (xii) Whether or not a tether is being used, the paratriathlete and guide shall not be more than 0.5 metres apart at all times.
- (xiii) As the TRI 6 paratriathlete crosses the finish line, the guide must be beside or behind the paratriathlete but not further apart than the required 0.5 metres maximum separation distance.
- (xiv) The guide must abide by all the competition rules that also pertain to the TRI 6 paratriathlete.

## **18. WINTER TRIATHLON:**

### **18.1. Definition:**

- a.) Winter Triathlon consists of running, mountain biking and cross country skiing. All segments of the race will be preferably on snow. Depending on the circumstances, the run and bike segment can be moved to a different surface.

### **18.2. Official Training and Familiarization:**

- a.) Official training and familiarization sessions will be conducted by the Technical Delegate and the LOC. Athletes and coaches may attend these official training and familiarization sessions.
- b.) Conduct on race days: Athletes are not allowed to warm up or do any familiarization on the course while a race is in progress.

### **18.3. Run Segment:**

- a.) Running shoes are mandatory on the running segment. This rule is not applicable to age-group athletes;
- b.) Running shoes with spikes are allowed.

### **18.4. Mountain Bike Segment:**

- a.) The minimum tyre dimension is 26x1.5 inches (599-40), which means the smallest part of the tyre should not be less than 40mm;
- b.) The bike segment of winter triathlon competitions is laid out as a cross-country course over snow and may follow normal roads or paths;
- c.) Athletes are allowed to push or carry the bike over the course;
- d.) Drafting is allowed; for safety reasons it may be forbidden to pass other athletes before entering the Transition Area. Lapped athletes will be not removed from the race;
- e.) Athletes must bring their own tools and parts and must carry out their own repairs;
- f.) Bike shoes are mandatory in the bike segment. This rule is not applicable to age-group athletes;
- g.) Spiked tyres are allowed provided that the spikes are shorter than 5 mm. measured from the tyre surface.

### **18.5. Coaches Zone:**

- a.) Coaches will have one space to feed their athletes in a designated zone on both the bike and ski segments.

### **18.6. Ski Segment:**

- a.) Testing of equipment (skis) is allowed prior to the race on specially marked tracks, or on the race-course, if announced by the Technical Officials;
- b.) Athletes cannot be accompanied by team members, team managers or other pacemakers on the course, during the race;
- c.) Athletes are allowed to change one ski and both poles;
- d.) Athletes may ski using their preferred technique;
- e.) Specified zones may have restrictions to classic style or double poling;
- f.) Wearing the bike helmet during the ski segment is not allowed. However, due to the effect of cold temperatures on mobility, wearing a helmet could be authorised by the TD;

- g.) Once a request to pass is made by a athlete, the athlete being passed must move to the side as soon as possible;
- h.) In the finish chute (30-50m), skiing freestyle may be forbidden. Double poling may be required. Prepared tracks must then be used. This circumstance will be announced in the athletes' briefing;
- i.) Athletes cannot remove their skis until at least 10 metres past the finish line. The last ski check will take place after this line;
- j.) Ski shoes are mandatory in the cross country ski segment. This rule is not applicable to age-group athletes.

**18.7. Transition Area Conduct:**

- a.) Skiing inside the transition area is forbidden;
- b.) In the transition area, Technical Officials may assist athletes by receiving and placing their bikes and handing out their equipment. This service must be equal for all athletes.

**18.8. Finish Definition:**

- a.) An athlete will be judged as "finished," the moment the tip of the front ski boot crosses the finish line.

**18.9. Weather conditions:**

- a.) The race will be cancelled when the air temperature is lower than -18°.

## **19. CROSS TRIATHLON AND DUATHLON:**

### **19.1. General:**

- a.) Cross Triathlon consists of swimming, mountain biking (MTB) and cross-country running.
- b.) Cross Duathlon consists of cross-country running, mountain biking (MTB) and cross-country running.

### **19.2. Distances:**

- a.) The distance of Cross Triathlon is outlined in Appendix A.
- b.) The distance of Cross Duathlon is outlined in Appendix A.
- c.) The course should have demanding hills and challenging technical aspects. A 5% tolerance margin will be accepted for the distance of the bike course, provided it has been approved by the Technical Delegate.

### **19.3. Official Training and Familiarization:**

- a.) Official training and familiarization sessions will be conducted by the Technical Delegate and the LOC. Athletes and coaches may attend these official training and familiarization sessions.
- b.) Conduct on race days: Athletes are not allowed to warm up or do any course familiarization while a race is in progress.

### **19.4. Mountain Biking Conduct:**

- a.) The maximum tyre diameter for the MTB is 29 inches. The minimum cross section is 1.5 inch, (599-40), which means the smallest part of the tyres should not be less than 40mm.
- b.) Studded and/or slick tyres are allowed.
- c.) Athletes are allowed to push or carry the bike over the course.
- d.) Lapped athletes will be not removed from the race.

### **19.5. Running Conduct:**

- a.) Spike shoes are allowed.

## 20. COMPETITION IN QUALIFYING ROUND FORMAT:

### 20.1. General:

- a.) A competition in Qualifying Round Format consists of several rounds with a number of heats each qualifying athletes to the next round and eventually finishing with a final to determine a winner.

### 20.2. Rounds:

- a.) The rounds will be called semifinals and final.
- b.) A competition will have two rounds.
- c.) Semifinals and final will have 30 athletes as a maximum. The number of semifinals will be as follows.

Athletes entered	Semifinals
Less than 30	No semifinals, direct final
31 to 60	2 semifinals (15 to 30 athletes each)
61 to 90	3 semifinals (20 to 30 athletes each)
91 to 120	4 semifinals (22 to 30 athletes each)
121 to 150	5 semifinals (24 to 30 athletes each)

### 20.3. Qualification to final

- a.) Every semifinal will qualify a fixed number of athletes for the final. Additionally a number of athletes will qualify from all of the semifinals by times.

Athletes entered	Semifinals	By position in the semifinal	By time
31 to 60	2	14	2
61 to 90	3	9	3
91 to 120	4	7	2
More than 121	5	5	5

- b.) Athletes from different heats and with the same time (in seconds), which are tied in the last qualifying position, will all qualify, increasing the number of athletes qualified for the next round.
- c.) Athletes who have not qualified for the final will be sorted by time. In case of athletes withdrawing from the final, replacement will be made by the first athlete who has not qualified. The replacement will happen if the number of athletes in any of the heats of the phase drops down to 30 athletes. (a random selection will be made made from those athletes who have the same time). The deadline for the replacements will be when registration opens.

### 20.4. Distribution of athletes in the semifinals.

- a.) The TD will compose the heats as follows:
  - (i) If there are not any applicable rankings, the athletes will be distributed among the heats in order to have the same number of athletes per semifinal (some semifinals can have one more athlete than others). The athletes from the same NF will be distributed among the heats following the same principle.
  - (ii) If a ranking is applicable, the ranked athletes will be distributed according to the chart below and the non-ranked athletes will fill the remaining spots by applying the principle of assigning a similar number of athletes from the same NF to every heat, and keeping all the heats of equal size.

Chart . Distribution of ranked athletes among the semifinals.

Semifinal 1	Semifinal 2	...	Semifinal (-1)	Last semifinal
1				
	2			
			3	
				4
				5
			6	
	7			
8				
9				
	10			
			11	
				12
				13
			14	
	15			
16				
17				
Etc...				

The number reflects the ranking order

#### 20.5. Numbering.

- a.) The principles in paragraph 20.8 will apply for numbering purposes in the semifinal and final rounds.

#### 20.6. Results.

- a.) The overall results for the event will be the results of the final round.
- b.) If the event is included in any ranking which is allocating points to more positions than finishers in the final, the remaining points will be awarded as follows:
  - (i) To the DNF athletes in the final, according to their times in the semifinals,
  - (ii) To the DNS athletes in the final according to their times in the semifinal,
  - (iii) To the athletes who did not qualify to the final, according to their times in the semifinals.
  - (iv) If the cut off time is before the last qualified athlete in the final, athletes not finishing the final round will not earn points.
  - (v) DSQ athletes will not earn any points.

#### 20.7. Prize money:

- a.) Prize money distribution will follow the general rules (Appendix I) and the preceding paragraph if necessary.





## **APPENDICES**

2012 Edition



## 21. APPENDIX A: RACE DISTANCES AND AGE REQUIREMENTS:

### Triathlon:

	Swim	Bike	Run	Minimum age required
Team Relay	250 to 300 m	5 to 8 km	1.5 to 2 km	16
Super Sprint Distance	250 to 500 m	6.5 to 13 km	1.7 to 3.5 km	16
Sprint Distance	Up to 750 m	Up to 20 km	Up to 5 km	16
Standard Distance	1500 m	40 km	10 km	18
Long Distance	1000 to 4000 m	80 to 180 km	10 to 42.2 km	18
Double Olympic (O2)	3000 m	80 km	20 km	18
Triple Olympic (O3)	4000 m	120 km	30 km	18

### Duathlon:

	Run	Bike	Run	Minimum age required
Team Relay	2 km	8 km	1 km	16
Sprint Distance	5 km	20 km	2,5 km	16
Standard Distance	10 km	40 km	5 km	18
Long Distance	20 km	80 km	10 km	18

### Aquathlon:

	Run	Swim	Run	Minimum age required
Standard Distance	2.5 km	1000 m	2.5 km	16
Standard Distance (cold waters)		1000 m	5 km	16
Long Distance	5 km	2000 m	5 km	18
Long Distance (cold waters)		2000 m	10 km	18

### Winter Triathlon:

	Cross-Country Run	Mountain Bike	Cross-Country Ski	Minimum age required
Team Relay	2 to 3 km	4 to 5 km	3 to 4 km	16
Sprint Distance	3 to 4 km	5 to 6 km	5 to 6 km	16
Standard Distance	7 to 9 km	12 to 14 km	10 to 12 km	18

**Cross Triathlon:**

	<b>Swim</b>	<b>Mountain Bike</b>	<b>Cross Country Run</b>	<b>Minimum age required</b>
Team Relay	200 m	4 to 5 km	1.2 to 1.6 km	16
Sprint Distance	500 m	10 to 12 km	3 to 4 km	16
Standard Distance	1000 m	20 to 25 km	6 to 8 km	18

**Cross Duathlon:**

	<b>Cross Country Run</b>	<b>Mountain Bike</b>	<b>Cross Country Run</b>	<b>Minimum age required</b>
Team Relay	1.2 to 1.6 km	4 to 5 km	0.6 to 0.8 km	16
Sprint Distance	3 to 4 km	10 to 12 km	1.5 to 2 km	16
Standard Distance	6 to 8 km	20 to 25 km	3 to 4 km	18

## 22. APPENDIX B: RACE PROTEST FORM:



INTERNATIONAL TRIATHLON UNION

### PROTEST FORM

**Part 1:** To be completed by the protester.

Protest must be filed and signed by the protester under the conditions outlined in the ITU Competition Rules and submitted to the Referee.

<b>Event Name:</b> _____	<b>Event Date:</b> _____
<b>Event Location:</b> _____	
<b>Name of Protester:</b> _____	<b>Race Number:</b> _____
<b>Country of Protester:</b> _____	<b>Email:</b> _____
<b>Address of Protester:</b> _____	
<b>Telephone (home):</b> _____	<b>Telephone (mobile):</b> _____
<b>Name of Protestee:</b> _____	<b>Race Number:</b> _____
<b>Country of Protestee:</b> _____	_____

A protest is a formal complaint against the conduct of a fellow athlete or race official, or against conditions of the Competition. You must have substantial evidence, including witnesses, and you must be willing to take part in an interview. Any protest must be accompanied with a cheque or cash for \$50 USD or equivalent currency.

What type of Protest is involved? (Check one box only.)

- Protest Concerning the Course
- Protest Against Another Athlete or a Technical Official
- Protest Concerning Eligibility
- Protest Concerning Timekeeping
- Protest Concerning Equipment

**Witness Details (2):**

**Name of Witness 1:** \_\_\_\_\_  
**Name of Witness 2:** \_\_\_\_\_

**Rule(s) Violated:** \_\_\_\_\_ **Time of Incident:** \_\_\_\_\_



**Where did the Violation occur (Define location. If required use additional paper and draw a diagram.)**

---

---

---

**Who was involved in the Violation?**

---

---

**How did the Violation occur (brief statement explaining alleged violation)?**

---

---

---

**Signature of Protester:**

---

Date:

---

Part 2: To be completed by Referee

**Time received by Race**

**Fee attached?** Yes  No

**Referee:**

---

**Protester's version of the incident:**

---

---

**Protestee's version of the incident:**

---

---

**Official's version of the incident:**

---

---

**Decision of Referee:**

---

---

**Referee's Name:**

---

Signature

---

### 23. APPENDIX C: RACE APPEAL FORM:



INTERNATIONAL TRIATHLON UNION

#### APPEAL FORM

**Part 1:** To be completed by the appellant:

Appeals must be filed and signed by the appellant under the conditions outlined in the ITU Competition Rules, and submitted to the Technical Delegate. An appeal is a request for a review of a decision made by the Referee. This is the first level of appeal and will be heard by the Competition Jury. All appeals must be accompanied with a cheque or cash for \$50 USD or equivalent currency.

<b>Event Name:</b>	_____	<b>Event Date:</b>	_____
<b>Event Location:</b>	_____	<b>Time Appeal Submitted:</b>	_____
<b>Name of Appellant:</b>	_____	<b>Race Number:</b>	_____
<b>Country of Appellant:</b>	_____	<b>Email:</b>	_____
<b>Address of Appellant</b>	_____		
<b>Telephone (home):</b>	_____	<b>Telephone (mobile):</b>	_____
<b>Type of Penalty Received</b>		<b>Type of Penalty: (DQ, Suspension):</b>	_____
Was the Penalty confirmed by the Referee?	<b>Yes</b> <input type="checkbox"/>	<b>No</b> <input type="checkbox"/>	_____

**Type of Appeal:** (Check one box only.)

- Appeal against the Referee's ruling on a Violation Report
- Appeal against the Referee's ruling on a Protest:

**Specific Location on the Course:** \_\_\_\_\_  
\_\_\_\_\_

**Name and Number of Race Official(s) / Athlete(s) / Spectator(s) if Known** \_\_\_\_\_  
\_\_\_\_\_

**Description of the Incident (Use additional paper if required)** \_\_\_\_\_  
\_\_\_\_\_  
\_\_\_\_\_



**Witness Details (2):**

**Name of Witness 1:** \_\_\_\_\_

**Name of Witness 2:** \_\_\_\_\_

**Date:**

**Signature of Appellant:** \_\_\_\_\_

**Part 2 Official use only**

<b>Appeal Fee \$50 USD attached</b>	Yes <input type="checkbox"/>	No <input type="checkbox"/>
<b>Is this Appeal to reverse a Competition Jury decision?</b>	Yes <input type="checkbox"/>	No <input type="checkbox"/>
<b>If 'Yes', attach Competition Jury Decision and action(s) and Referee's decision and action(s).</b>		
<b>Competition Jury Members (Names) and tick box to indicate if it was a 3 person jury or 5 person.</b> <input type="checkbox"/> 3 person jury <input type="checkbox"/> 5 person jury	1.	
	2.	
	3.	
	4.	
	5.	
<b>Competition Jury Action:</b>		
<b>Competition Jury Chair's Name Signature:</b>		
<b>Time, Date Appeal Received:</b>		
<b>Time, Date Appeal processed:</b>		
<b>Amount of fee withheld/refunded:</b>		

## 24. APPENDIX D: DEFINITIONS:

<b>Age</b>	The age of the athlete on the 31st of December of the year of the competition.
<b>Aid/Outside Assistance:</b>	Any food, drink, equipment or relief allowed by the ITU Competition Rules.
<b>Appeal:</b>	A request to the Competition Jury of an event or the ITU Executive Board for a review of the decision of the Referee/Competition Jury. (Note: This cannot include an appeal against the finding of a doping violation or against the penalty imposed for the finding of a doping violation. These appeals must be directed to the ITU Executive Board independently.)
<b>Appellant</b>	An athlete submitting an appeal.
<b>Aquathlon</b>	The term recognised by the ITU for a sport of individual character and motivation that combines swimming and running skills in continuum.
<b>Assistance</b>	Any attempt by an unauthorised or unofficial source to help or to stabilise an athlete.
<b>Assistant Chief Technical Official</b>	Responsible to the Chief Technical Official for coordinating the employment of the Technical Officials assigned to his/her race course segment or area.
<b>Athletes</b>	The competitors who register for and compete in ITU events.
<b>Athletes' Briefing</b>	The meeting for elite athletes conducted by the Technical Delegate at 17h00 local time two days prior to the first elite competition day for ITU World Championships and ITU Triathlon World Cups, and 1 day prior to the first elite competition day for all other ITU events.
<b>Bike Course</b>	Part of the race course over which it has been defined in the Athletes' Briefing the bike is to be ridden, walked or carried within distinctive lane boundaries. The bike course commences from the Mount Line and concludes at the Dismount Line.
<b>Blocking</b>	The deliberate impeding or obstructing of progress of one athlete by another. An athlete on the bike course, who is not keeping to the appropriate side of the road.
<b>Charge</b>	The contacting of one athlete by another from the front, rear or side, and hindering that athlete's progress.
<b>Chief Technical Official</b>	Appointed by the Referee and is responsible for the control and co-ordination of the deployment of Technical Officials.
<b>Clean Start</b>	All the athletes start after the horn. The race continues.
<b>Competition Jury</b>	The Jury appointed and chaired by the Technical Delegate. It is held responsible to determine, to hear and to rule on all appeals against decisions handed down through the Referee, including decisions on protests.
<b>Competition Rules</b>	The official ITU Competition Rules, which govern all triathlon and other related Multisports events worldwide, unless that sport is under the jurisdiction of an international governing body recognised by IOC, CISM or SportAccord.
<b>Continental Technical</b>	The Level 2 Technical Officials certified by ITU.



## **Officials (CTOs)**

<b>Course</b>	A forward line of progress from start to finish, which must be clearly marked and measured to prescribed specifications.
<b>Crawling</b>	The action by an athlete of bringing three or more limbs in contact with the ground, either together or in any sequence, to enable forward propulsion.
<b>Dismount Before The Mount Line</b>	An athlete's foot must contact the ground entirely before the dismount line. If this contact doesn't occur, it is considered an infringement of the rules.
<b>Dismount Line</b>	A designated line at the entrance of the Transition Area from the bike course before which athletes are to dismount their bikes fully and proceed to the bike racks. The Dismount Line will normally extend for the width of the entrance to the Transition Area and be identified by flags/line/Technical Official, or combinations thereof.
<b>Disqualification</b>	A penalty assigned as appropriate for the rule violation, which has been reported, or for which a protest has been upheld. As a result of this penalty, the athlete will not be given finish or split times for the event, no account will be taken of the athlete when placings are assessed for any category or for the race as a whole, and the athlete's results will appear as DSQ.
<b>Draft Zone Bicycle</b>	The draft zone is a rectangle created by every athlete in which other athletes can enter for a limited period of time and for overtaking purposes. The dimensions of the draft zone are dependent on the race distance.
<b>Draft Zone Vehicle</b>	The draft zone for a motor vehicle is a rectangle 35 metres long and 5 metres wide which surround every vehicle on the bike course. The centre front of the vehicle defines the centre of the leading 5-metre edge of the rectangle.
<b>Drafting</b>	Any time the draft zone of an athlete overlaps the draft zone of another athlete, vehicle or motorcycle on the bike course of an event.
<b>Duathlon</b>	The term recognised by the ITU for a sport of individual character and motivation, which combines cycling and running skills in continuum.
<b>Early start</b>	When an athlete's foot crossed the vertical plane of the start line, before the start signal.
<b>Elite</b>	Elite athletes are those competing in elite races.
<b>Event Organisers Manual (EOM)</b>	A document which has been developed to ensure the implementation of consistently high global event management and marketing standards.
<b>Expulsion</b>	An athlete penalised by expulsion will not be permitted, during his or her lifetime, to take part in any ITU sanctioned event, or any event sanctioned by one of its member associations (National Federation) affiliated with the ITU.
<b>Field of Play (FOP)</b>	The course on which the competition portions of the ITU event will take place.
<b>Final</b>	Last round of an event in qualifying round format. The final decides the winner and the medallist of the event.
<b>Finisher</b>	An athlete who completes the entire race course within the rules and crosses the finish line, or a vertical extension of the forward edge of the finish line, with any part of the torso (i.e. as distinct from the head, neck,

arms, legs, hands or feet).

<b>Force Majeure</b>	Action of the elements, strike, lockout or other industrial disturbance, unlawful act against public order or authority, war blockade, public riot, lightning, fire or explosion, storm, flood, blacklisting, boycott or sanctions however incurred, freight embargo, transportation delay or any other, event which is not reasonably within the control of the party affected.
<b>Incapable Athlete</b>	An athlete deemed by race medical staff as not being able to continue the event without the likelihood of causing injury to him/herself or another athlete.
<b>Indecent Exposure</b>	The willful uncovering of either or both buttocks, or of the pubic area or of the genital area. In addition, in the case of a female athlete, the willful complete uncovering of one or both nipples.
<b>Interference</b>	A deliberate block, charge or abrupt motion, which impedes another athlete.
<b>International Technical Officials (ITOs)</b>	The Level 3 Technical Officials certified by ITU.
<b>International Triathlon Union (ITU)</b>	The world governing body of triathlon, duathlon, aquathlon, winter triathlon and all other related multisport, a non-profit corporation incorporated under the laws of Canada, domiciled and residing at #221-998 Harbourside Dr., in the city of North Vancouver, Province of British Columbia, Canada.
<b>ITU Competition Rules</b>	The document that contains all the rules and regulations that governs fair and safe competitions.
<b>ITU Members</b>	The National Federations and Continental Confederations affiliated to ITU.
<b>ITU Rules</b>	The ITU Event Organisers' Manual (latest edition), ITU Competition Rules, ITU Constitution and By-Laws, ITU Uniform Rules, ITU Anti-Doping Rules and WADA Code, ITU Athletes' Agreement, ITU Qualification Criteria, ITU Ranking Criteria and any other rules adopted and amended by ITU from time to time and available for consultation via the download section of the ITU's official website <a href="http://www.triathlon.org">www.triathlon.org</a> .
<b>Invalid Start</b>	Some athletes start clearly before the horn and some others stay behind the start line. The start is not clean and is declared invalid.
<b>Local Organising Committee (LOC)</b>	The organising entity of an ITU event.
<b>Mount After The Mount Line</b>	An athlete's foot must contact the ground entirely past the mount line. If this contact doesn't occur, it is considered an infringement of the rules.
<b>Mount Line</b>	A designated line at the exit from the Transition Area onto the bike course or after which athletes are to mount their bicycles and proceed. The Mount Line will normally extend for the width of the exit of the Transition Area and be identified by flags/line/Technical Official, or combinations thereof.
<b>National Federation (NF)</b>	National triathlon governing body affiliated with ITU.
<b>National Technical</b>	The Level 1 Technical Officials certified by the NF.

## **Officials (NTOs)**

<b>Overtake</b>	On the bike course, when the leading edge of the front wheel of the overtaking bike moves in front of the leading edge of the front wheel of the bike being overtaken. An athlete can pass another athlete only on the appropriate side.
<b>Pack</b>	Two or more athletes with overlapping draft zones.
<b>Pass</b>	When one athlete's bike draft zone overlaps another athlete's bike draft zone, makes continual forward progress through that zone and overtakes within a maximum period of 15 seconds (for standard distance events or shorter events) or 20 seconds (for long distance events). An athlete can pass another athlete only on the appropriate side.
<b>Penalty</b>	The consequence on an athlete, who is assessed by an ITU Technical Official to have unintentionally committed a rule infringement/violation. A penalty may take the form of a time delay, disqualification, suspension or expulsion.
<b>Penalty Box</b>	An area on the bike course or the run course, set aside for the implementation of a time penalty for a rule infringement/violation.
<b>Protest</b>	A formal complaint against the conduct of another athlete or a race official, or against the conditions of the competition.
<b>Referee</b>	A Technical Official, who is responsible to the Technical Delegate to hear and make final decisions on all rules violations reported by Technical Officials.
<b>Results</b>	The timed finish positions of all athletes after violation reports have been ruled on, protests and appeals have been heard, and penalties have been awarded.
<b>Right of Way</b>	When an athlete has established a lead position and pursues a desired course within the limits of the ITU Competition Rules.
<b>Round</b>	Each of the stages of an event with qualifying format. One event in qualifying round format has two rounds: semifinals and final.
<b>Run Course</b>	Part of the race course, which has been defined at the Athletes' Briefing where the athlete is to run or walk within distinctive lane boundaries. In triathlons and aquathlons, the run course commences at the exit from the Transition Area and concludes at the Finish Line. In duathlons, the first run course commences at the start line and finishes at the entry to the Transition Area; the second run course commences at the exit from the Transition Area and concludes at the Finish Line.
<b>Sanction</b>	A permit issued by the National Federation for the conduct of an event. The issue of such a permit is a declaration by the sanctioning authority that plans for the event have been thoroughly inspected and have been found to comply fully with the requirements of National Federation operating requirements to provide the greatest potential for the conduct of a safe and fair event.
<b>Semifinal</b>	Preliminary round of an event in qualifying round format. The semifinals determine the athletes qualified to the final.
<b>Sports Conduct</b>	The behaviour of an athlete during competition. Previously referred to as 'sportsmanship', good sports conduct is interpreted as fair, rational and courteous behaviour, while bad sports conduct is any behaviour judged to be unfair, unethical or dishonest, a violent act, intentional misconduct, abusive language, intimidating behaviour, or persistent

	infringement of the rules.
<b>Standard Bridge Piece</b>	A rigid piece, of plastic or metal, which joins both sides of the handlebar clip-on at the ends and is commercially available.
<b>Stop and Go Time Penalty</b>	A method of imposing a brief delay on an athlete who is assessed by a Technical Official to have unintentionally infringed the rules, for example, drafting on the bike course. A Penalty Box may be used for this penalty.
<b>Suspension</b>	<p>An athlete awarded this penalty will not be permitted during the stated suspension period, to take part in any event sanctioned by ITU or its member associations (where determined) affiliated with ITU.</p> <p>For any suspension because of a doping violation, the athlete will not be able to compete in any IOC affiliated sport at any local, regional, state, national or international level. The suspension period may vary in length, depending on the severity of the violation. In the case of a suspension imposed by ITU, the length of the suspension will be determined by the ITU Executive Board.</p>
<b>Swim Course</b>	Part of the race course over which it has been defined in the Athletes' Briefing that the athlete is to swim within distinctive lane boundaries. In triathlons and aquathlons, the swim course commences at the start line and concludes at the water's edge/exit prior to entry to the Transition Area.
<b>Technical Delegate</b>	A Technical Official, who is qualified by ITU, and responsible for ensuring all aspects of the ITU Competition Rules and ITU Event Organisers' Manual are fulfilled in preparation for, during, and after the event. Where appeals are lodged, the Technical Delegate will be the chair of the Competition Jury. The Technical Delegate will normally be responsible for conducting or overseeing the conduct of event sanctioning.
<b>Technical Official</b>	A member of the joint team of International Technical Officials (ITOs), Continental Technical Officials (CTOs) and National Technical Officials (NTOs) at an ITU event.
<b>Torso</b>	Section of the body extending from the base of the neck to the base of the sternum.
<b>Transition Area</b>	A location within a defined boundary, which is not a part of the swim course, the bike course or the run course and within which each athlete is allocated an area for the storage of individual items of clothing and equipment.
<b>Triathlon</b>	A sport of individual or team character and motivation, which combines swimming, cycling and running skills in continuum.
<b>Valid Start with Early Starters</b>	Almost all the athletes start after the horn, but few of them did start before the horn. The start is declared valid and the early starters will receive a time penalty warning in T1.
<b>Venue</b>	All warm-up and competition areas, the air space above such areas, official hotel, broadcasters, press and media areas, sport expo area, contiguous areas, including without limitation spectators' area, VIP areas, transition area, finish area and all other areas under control of LOC.
<b>Violation</b>	A rule infringement which results in a penalty.
<b>Warning</b>	A verbal caution issued by a Technical Official to an athlete during the course of a race. The purpose of a warning is to alert the athlete of the potential for a rule violation to occur and to promote a pro-active attitude.

## 25. APPENDIX E1.

### ITU World Triathlon Series QUALIFICATION CRITERIA

#### 1. ELITE:

##### 1.1. ITU World Triathlon Series events:

- a.) Gold Group: ITU will determine a group of athletes called Gold Group<sup>1</sup>. The qualification criteria to be part of the Gold Group are described in the document called "ITU World Triathlon Series - Athletes benefits" and can be found on [www.triathlon.org](http://www.triathlon.org).
- b.) The National Federations must enter the athletes (including those in the Gold Group) into the wait list via the ITU online entry system no fewer than 33 days before the first competition day.
- c.) 32 days before the first competition day, the start list for both the men's and women's will be published on [www.triathlon.org](http://www.triathlon.org) adding athletes from the waitlist in the following order:
  - (i) Athletes from the Gold Group;<sup>2</sup>
  - (ii) 30 athletes with the best ranking from the current ITU Triathlon World Championship Rankings. If, at the time of this selection, there is no ranking from the current year, then the final rankings from the previous year will be used;
  - (iii) 20 athletes with the most points from the current ITU Points List, excluding those already on the start list. This number can be increased to put 60 athletes on the start list;
  - (iv) The remaining athletes on the wait list will be ordered by their position on the ITU Points List as per 32 days before the first competition day. Athletes without any ITU points will be ordered at the bottom of the wait list according to the time of their entry.
- d.) National Federation quota in each of the men's and women's event:
  - (i) Maximum per National Federation is 6 athletes.
  - (ii) Maximum per host National Federation is 8 athletes.
  - (iii) Gold Group athletes will not be included in their National Federation's maximum quota.
  - (iv) Maximum per National Federation and host National Federation may be increased by a maximum of 4 quota places if by step 1.1. c) (iii) the number of athletes on the start list is lower than 60.
- e.) Late Entries: Entries received 32 or fewer days before the first competition day will be placed at the bottom of the wait list at the time the National Federation entered the athlete into the ITU online entry system.

---

<sup>1</sup> Gold Group will be removed on October 22<sup>nd</sup> 2012. All the reference to the Gold Group in this Competition Rules will be valid only till this day.

<sup>2</sup> In the case of the event taking place together with the Team Relay World Championships the first criteria will be: the best two athletes (one man and one woman) in the ITU points list from the NFs with a team entered in the Team relay World Championships. The number of athletes coming from the ITU Points lists(<sup>3</sup><sup>rd</sup> bullet) will be decreased if necessary.

- f.) Substitutions: Each National Federation will be allowed to substitute 1 athlete per gender per event. The names of both athletes involved in the substitution must be emailed to [entries@triathlon.org](mailto:entries@triathlon.org). Substitutions are only allowed up to 12 days prior to the first competition day. There are no substitutions for athletes in the Gold Group. If the substitute athlete is ranked higher than the worse ranked athlete qualified for the start list, this substitution doesn't affect the quota of substitution.
- g.) Withdrawals: An athlete who is withdrawn from the start list will be replaced by the next athlete on the wait list. According to the rule 2.6.c) (iii) Athletes not attending the briefing, without informing the TD about their absence, will be removed from the start list. In this case, athletes from the wait list who attended the briefing will be called to fill the empty slots. Athletes present in the race briefing and still remaining on the wait list must stay nearby and in close contact in order to take the place of any upcoming withdrawals, until registration closes.
- h.) Invitations: 26 days before the first competition day, ITU will award a maximum of 5 invitations based on the requests emailed by respective National Federations to [entries@triathlon.org](mailto:entries@triathlon.org) and they will be put on the start list. If ITU awards less than 5 invitations, the remaining spot will be filled by the next athlete on the wait list.
- i.) If a National Federation withdraws an athlete from the start list within 25 days of the competition they must email [entries@triathlon.org](mailto:entries@triathlon.org). If there is a second withdrawal within 25 days of the first day of competition by the same National Federation, the country will lose 1 quota spot for the following 2 ITU World Triathlon Series events and the maximum quota of the National Federations affected will be adjusted accordingly for those events. This penalty could carry over to the following year.
- j.) National Federations withdrawing an athlete from the start list after the Monday at 13:00 GMT prior to the event, the athlete will be removed from all start lists and wait lists of any ITU events for the next 30 days and will not be reinstated in any of the races on the same weekend as the race from which they were withdrawn. A number of unexpected withdrawals without being penalized because last minute issues are fixed. This number depends on the number of participations of each NF over the previous year, as follows.

Number of late withdrawals not penalized (*)	Nations for 2012 (*)
6	AUS, GBR, GER, JPN, RUS, USA
5	ESP, NZL
3	CAN, FRA, POR, RSA, SUI
2	All the others

*(\*) This includes men and women events in all WTS events, the Grand Final and World Cup events.*

- k.) An athlete not personally present at the Athletes' Briefing and who has not provided prior notification to the Technical Delegate by email or by phone will be removed from all start lists and wait lists of any ITU events for the next 30 days and will not be reinstated in any of the races on the same weekend as the race from which they were withdrawn.
- l.) Athletes present at the Athletes' Briefing but are forced to withdraw from the competition due to last minute illness or injury, as proven by a certificate from a medical doctor, will remain on future start lists and wait lists of all ITU events.

## 1.2. ITU World Triathlon Series Grand Final:

- a.) Gold Group: ITU will determine a group of athletes called Gold Group. The qualification criteria to be part of the Gold Group are described in the document called "ITU World Triathlon Series - Athletes benefits" and can be found on [www.triathlon.org](http://www.triathlon.org)

- b.) The National Federations must enter the athletes (including those included in the Gold Group) into the wait list via the ITU online entry system no fewer than 26 days before the first competition day.
- c.) 25 days before the first competition day, the start list for both the men's and women's will be published on [www.triathlon.org](http://www.triathlon.org) adding athletes from the waitlist in the following order:
  - (i) Athletes from the Gold Group.
  - (ii) 25 athletes with the best ranking from the current ITU World Triathlon Series Rankings.
  - (iii) 15 athletes with the most points from the current ITU Points List, excluding those already on the start list. This number can be increased to put 50 athletes on the start list.
  - (iv) The top 3 finishers of the last ITU Triathlon Continental Championships in elite category from all 5 continents. If the athlete is qualified by the first 3 bullets above, the spots will be allocated according to the ITU Points List.
  - (v) The remaining athletes on the wait list will be ordered by their position on the ITU Points List as per 25 days before the first competition day. Athletes without any ITU points will be ordered at the bottom of the wait list according to the time of their entry.
- d.) 20 days before the first competition day, 5 more athletes from the waitlist will be added to both the men's and women's start list with the most points from the current ITU Points List.
- e.) National Federation quota in each of the men's and women's event:
  - (i) Maximum per National Federation and host National Federation is 6 athletes.
  - (ii) Gold Group athletes will not be included in their National Federation's maximum quota.
  - (iii) Maximum per National Federation and host National Federation may be increased by a maximum of 4 quota places if by step 1.2. c) the number of athletes on the start list is lower than 70.
- f.) Late Entries: Entries received 25 or fewer days before the first competition day will be placed at the bottom of the wait list at the time the National Federation entered the athlete into the ITU online entry system.
- g.) Substitutions: Each National Federation will be allowed to substitute 1 athlete per gender per event. The names of both athletes involved in the substitution must be emailed to [entries@triathlon.org](mailto:entries@triathlon.org). 1 extra substitution is allowed if the substituted athlete is entered in the ITU Triathlon U23 World Championships instead of the elite events of the ITU World Championship Grand Final. Substitutions are only allowed up to 12 days prior to the first competition day. If the substitute athlete is ranked higher than the worse ranked athlete qualified for the start list, this substitution doesn't affect the quota of the substitution.
- h.) Withdrawals: An athlete who is withdrawn from the start list will be replaced by the next athlete on the wait list. According to the rule 2.6.c) (iii) Athletes not attending the briefing, without informing the TD about their absence, will be removed from the start list. In this case, athletes from the wait list who attended the briefing will be called to fill the empty spots. Athletes present in the race briefing and still remaining on the wait list must stay nearby and in close contact in order to take the place of any upcoming withdrawals, until registration closes.

- i.) Invitations: 20 days before the first competition day, ITU will award a maximum of 5 invitations based on the requests emailed by respective National Federations to [entries@triathlon.org](mailto:entries@triathlon.org) and they will be put on the start list. If ITU awards less than 5 invitations, the remaining spot will be filled by the next athlete on the wait list.
- j.) Athletes' Briefing: will take place at 17:00, 2 days before the first day of competition.
- k.) If a National Federation withdraws an athlete from the start list within 20 days of the competition they must email [entries@triathlon.org](mailto:entries@triathlon.org). If there is a second withdrawal within 20 days of the first day of competition by the same National Federation, the country will lose 1 quota spot for the following 2 ITU World Triathlon Series events and the maximum quota of the National Federations affected will be adjusted accordingly for those events. This penalty could carry over to the following year.
- l.) National Federations withdrawing an athlete from the start list after the Monday at 13:00 GMT prior to the event, the athlete will be removed from all start lists and wait lists of any ITU events for the next 30 days and will not be reinstated in any of the races on the same weekend as the race from which they were withdrawn. A number of unexpected withdrawals without being penalized because last minute issues are fixed. This number depends on the number of participations of each NF the previous year, as follows.

Number of late withdrawals not penalized (*)	Nations for 2012 (*)
6	AUS, GBR, GER, JPN, RUS, USA
5	ESP, NZL
3	CAN, FRA, POR, RSA, SUI
2	All the others

(\*) This includes men and women events in all WTS events, the Grand Final and World Cup events.

- m.) Athletes not personally present at the Athletes' Briefing and who have not provided prior notification to the Technical Delegate by email or by phone will be removed from all start lists and wait lists of any ITU events for the next 30 days and will not be reinstated in any of the races on the same weekend as the race from which they were withdrawn.
- n.) Athletes present at the Athletes' Briefing but are forced to withdraw from the competition due to last minute illness or injury, as proven by a certificate from a medical doctor, will remain on future start lists and wait lists of all ITU events.

### 1.3. UNDER23:

- a.) The National Federations must enter their athletes into the wait list via the ITU online entry system no fewer than 33 days before the first competition day.
- b.) 32 days before the first competition day the start lists will be done considering the following qualification principles:
  - (i) Each National Federation in good standing with ITU has the right automatically to enter 2 athletes in the ITU Triathlon U23 World Championships.
  - (ii) Based on the number of athletes the National Federations had in the previous year's ITU Triathlon U23 World Championships results, they will be allowed 1 additional entry for a maximum of 3 in total per National Federation, if the NF had 2 or more athletes in the top 25 of the previous year's ITU Triathlon U23 World Championships.
- c.) Invitations places may be awarded to athlete by ITU upon request emailed by respective National Federations to [entries@triathlon.org](mailto:entries@triathlon.org) no later than 26 days prior to the ITU Triathlon U23 World Championships. Invitation places will be awarded 25



days prior to the ITU Triathlon U23 World Championships. ITU shall have the sole authority to award any or all of the invitation places.

- d.) If the number of athletes entered 32 days before the race is less than 70, National Federations can apply for maximum 2 more invitations exceeding their maximum quotas.

#### **1.4. JUNIOR:**

- a.) The National Federations must enter their athletes into the wait list via the ITU online entry system no fewer than 33 days before the first competition day.
- b.) 32 days before the first competition day the start lists will be done considering the following qualification principles:
- (i) The quota system for allocating the spots 1 to 70 is determined on the basis of the 5 continental confederations quotas.
  - (ii) The following were considered to create continental quotas:
    - The number of National Federations affiliated with ITU within the continent.
    - The number of National Federations that participated in the previous 2 ITU Triathlon Junior World Championships.
    - The number of National Federations that participated in the previous ITU Triathlon Junior Continental Championships.
  - (iii) Quotas per Continent (total: 70):
    - Africa: 4
    - Americas: 15
    - Asia: 9
    - Europe: 36
    - Oceania: 6
    - National Federation Maximum quota: 3
- c.) The Continental Championships considered as selection events have to take place a minimum of 45 days prior to the ITU Triathlon Junior World Championships. In case the ITU Triathlon Junior Continental Championships will take place after the 45 days term previously indicated, the Continental Confederation can apply to ITU to give the junior continental qualification status to another event. Spots will be awarded on a simple roll-down system through the results. As soon as a National Federation has 3 spots, additional spots will go to the next eligible National Federation on the results lists. Any place not claimed by a National Federation by entering the athlete through the ITU online entry system within 32 days of the ITU Triathlon Junior World Championships will be given to the Invitation places.
- d.) Host National Federation (spot 71 – if required): The host National Federation will get a minimum of 1 spot. If the host National Federation already has a spot from the ITU Triathlon Junior Continental Championships, the spot will go to the Invitation places.
- e.) Invitation: (spots 72 to 80): At the discretion of ITU, spots may be earned based on an athlete's past results and/or current rankings. This could include, but is not limited to, mechanical difficulties or illness at the ITU Triathlon Junior Continental Championships. National Federations must apply for an Invitational spot by email to [entries@triathlon.org](mailto:entries@triathlon.org) at least 26 days before the first competition day. Invitations will be awarded 25 days before the first competition day.
- f.) If the number of athletes entered 32 days before the race is less than 70, National Federations can apply for maximum 2 more invitations exceeding their maximum quotas.

## 1.5. AGE-GROUPS:

### a.) Olympic distance:

- (i) Qualification for the ITU Triathlon Age-Group World Championships Olympic distance will be:
  - Every National Federation can enter 20 athletes in every age-group.
  - The host National Federation has a larger quota of 25 athletes in every age-group.
  - The quota for any National Federation in any age-group can be increased at the discretion of ITU.

### b.) Sprint distance:

- (i) Qualification for the ITU Triathlon Age-Group World Championships Sprint distance will be:
  - Every National Federation can enter 20 athletes in every age-group.
  - The host National Federation has a larger quota of 25 athletes in every age-group.
  - The quota for any National Federation in any age-group can be increased at the discretion of ITU.

## 1.6. PARATRIATHLON

### a.) Qualification for the ITU Paratriathlon World Championships will be:

- (i) Every National Federation can enter 6 athletes in every Paratriathlon category.
- (ii) The host National Federation has a larger quota of 8 athletes in every Paratriathlon category.
- (iii) The quota for any National Federation in any Paratriathlon category can be increased at the discretion of ITU.

### ITU Triathlon World Cup QUALIFICATION CRITERIA

#### 1. ITU TRIATHLON WORLD CUP EVENTS

- a) The National Federations must enter the athletes into the wait list via the ITU online entry system no less than 33 days before the first competition day.
- b) 32 days before the first competition day, the men's and women's start lists will be published on [www.triathlon.org](http://www.triathlon.org) and adds athletes from the waitlist in the following order:
  - (i) 25 athletes with the best ranking from the current ITU Triathlon World Championship Rankings. If, at the time of this selection, there is no ranking from the current year, the final rankings from the previous year will be used.
  - (ii) 45 athletes with the most points from the current ITU Points List, excluding those already on the start list. This number can be increased to put 70 athletes on the start list.
  - (iii) The remaining athletes on the wait list will be ordered by their position on the ITU Points List as per 32 days before the first competition day. Athletes without any ITU points will be ordered at the bottom of the wait list according to the time of their entry.
- c) National Federation quota in each of the men's and women's event:
  - (i) Maximum per National Federation is 6 athletes.
  - (ii) Maximum per host National Federation is 8 athletes.
  - (iii) Maximum per National Federation and host National Federation may be increased by a maximum of 4 quota places if by step 1.1. c) (2nd bullet), or later the number of athletes on the start list is lower than 70.
- d) Late Entries: Entries received 32 or fewer days before the first competition day will be placed at the bottom of the wait list at the time the National Federation entered the athlete into the ITU online entry system.
- e) Substitutions: Each National Federation will be allowed to substitute 2 athletes per gender per event. The names of both athletes involved in the substitution must be emailed to [entries@triathlon.org](mailto:entries@triathlon.org). If the substitute athlete is ranked higher than the worse ranked athlete qualified for the start list, this substitution doesn't affect the quota of substitution.
- f) Withdrawals: An athlete who is withdrawn from the start list will be replaced by the next athlete on the wait list. According to the rule 2.6.c) (iii) Athletes not attending the briefing, without informing the TD about their absence, will be removed from the start list. In this case, athletes from the wait list who attended the briefing will be called to fill the empty spots. Athletes present in the race briefing and still remaining on the wait list must stay nearby and in close contact in order to take the place of any upcoming withdrawals.
- g) Invitations: 26 days before the first competition day, ITU will award invitations based on the requests emailed by respective National Federations to [entries@triathlon.org](mailto:entries@triathlon.org) and they will be put on the start list. The National Federation quota may be increased by a maximum of 2 more by awarding invitations.
- h) National Federations withdrawing an athlete from the start list after the Monday at 13:00 GMT prior to the event, the athlete will be removed from all start lists and wait lists of all ITU events for the next 30 days and will not be reinstated in any of the races on the same weekend as the race from which they were withdrawn.
- i) Athletes not personally present at the Athletes' Briefing and who have not provided prior notification to the Technical Delegate by email or by phone will be removed from all start lists and wait lists of all ITU events for the next 30 days and will not be reinstated in any of

the races on the same weekend as the race from which they were withdrawn. A number of unexpected withdrawals without being penalized because last minute issues are fixed. This number depends on the number of participations of each NF the previous year, as follows.

Number of late withdrawals not penalized (*)	Nations for 2012 (*)
6	AUS, GBR, GER, JPN, RUS, USA
5	ESP, NZL
3	CAN, FRA, POR, RSA, SUI
2	All the others

(\*) This includes men and women events in all WTS events, the Grand Final and World Cup events.

- j) Athletes present at the Athletes' Briefing but are forced to withdraw from the competition due to last minute illness or injury, as proven by a certificate from a medical doctor, will remain on future start lists and wait lists of all ITU events.

### ITU Triathlon Continental Cup 2010 QUALIFICATION CRITERIA

#### 1.1. ITU Triathlon Continental Cup events:

- a) The National Federations must enter the athletes into the wait list via the ITU online entry system no less than 33 days before the first competition day.
- b) 32 days before the first competition day, the men's and women's start lists will be published on [www.triathlon.org](http://www.triathlon.org) and adds athletes from the waitlist in the following order:
  - (i) Athletes with the most points from the current ITU Points List.
  - (ii) Athletes with the best ranking from the current ITU Continental Ranking (the continent where the event is held), excluding those already on the start list.
  - (iii) The remaining athletes will be placed on the wait list will be ordered by their position on the ITU Points List as per 32 days before the first competition day.
  - (iv) Athletes on the wait list not present on the current ITU Points List will be ordered by their position on the ITU Continental Ranking as per 32 days before the first competition day. (the continent where the event is held).
  - (v) Athletes on the wait list not present on the current ITU Points List and not present on the current ITU Continental Ranking (the continent where the event is held) will be ordered at the bottom of the wait list by choosing one per nation in alphabetical order of the Nation Code starting by the host Nation.
- c) National Federation quota in each of the men's and women's event:
  - (i) Maximum per National Federation is 10 athletes.
  - (ii) Maximum per host National Federation is 15 athletes.
  - (iii) Maximum per National Federation and host National Federation may be increased if by step 1.1. b) (2nd bullet) the number of athletes on the start list is less than 70.
- d) Late Entries: Entries received 31 or fewer days before the first competition day will be placed at the bottom of the wait list at the time the National federation entered the athlete into the ITU online entry system.
- e) Invitations: 26 days before the first competition day, ITU will award invitations based on the requests emailed by respective National Federations to [entries@triathlon.org](mailto:entries@triathlon.org) and they will be put on the start list. The National Federation quota may be increased by awarding invitations.
- f) Substitutions: Each National Federation will be allowed to substitute three athletes per event per gender. The names of both athletes involved in the substitution must be emailed to [entries@triathlon.org](mailto:entries@triathlon.org).
- g) Withdrawals: An athlete withdrawn from the start list will be replaced by the next athlete on the wait list.
- h) National Federations withdrawing athletes from the start list after the Monday at 13:00 GMT prior to the event, the athlete will be removed from all start lists and wait lists of all ITU events for the next 30 days and will not be reinstated in any of the races on the same weekend as the race from which they were withdrawn.
- i) Athlete not personally present at the Athletes' Briefing and who have not provided prior notification to the Technical Delegate by email or by phone will be removed from all start lists and wait lists of all ITU events for the next 30 days and will not be reinstated in any of the races on the same weekend as the race from which they were withdrawn.
- j) Athletes present at the Athletes' Briefing but are forced to withdraw from the competition due to last minute illness or injury, as proven by a certificate from a medical doctor, will remain on future start lists and wait lists of all ITU events.

**ITU Aquathlon World Championships  
QUALIFICATION CRITERIA**

**1. ELITE:**

- 1.1. National Federation quota for the ITU Elite Aquathlon World Championships in each of the men's and women's event:
- a) Maximum per National Federation is 6 athletes.
  - b) All qualified athletes for the ITU Elite Aquathlon World Championships need to be entered through their National Federations.
  - c) The quota for any National Federation can be increased at the discretion of ITU.

**2. UNDER23:**

- 2.1. National Federation quota for the ITU Aquathlon U23 World Championships in each of the men's and women's event:
- a) Maximum per National Federation is 6 athletes.
  - b) All qualified athletes for the ITU Aquathlon U23 World Championships need to be entered through their National Federations.
  - c) The quota for any National Federation can be increased at the discretion of ITU.

**3. JUNIOR:**

- 3.1. National Federation quota for the ITU Aquathlon Junior World Championships in each of the men's and women's event:
- a) Maximum per National Federation is 6 athletes.
  - b) All qualified athletes for the ITU Aquathlon Junior World Championships need to be entered through their National Federations.
  - c) The quota for any National Federation can be increased at the discretion of ITU.

**4. AGE-GROUPS:**

- 4.1. Qualification for the ITU Aquathlon Age-Group World Championships will be:
- a) Every National Federation can enter 20 athletes in every age-group.
  - b) The host National Federation has a larger quota of 25 athletes in every age-group.
  - c) All qualified athletes for the ITU Aquathlon Age-Group World Championships need to be entered through their National Federations.
  - d) The quota for any National Federation in any age-group can be increased at the discretion of ITU.
  - e) The age-group categories are indicated in the ITU Competition Rules.

**5. PARATRIATHLON:**

- 5.1. Qualification to the ITU Paratriathlon Aquathlon World Championships will be:
- a) Every National Federation can enter 6 athletes in every Paratriathlon category.
  - b) The host National Federation has a larger quota of 8 athletes in every Paratriathlon category.
  - c) All qualified athletes for the ITU Paratriathlon Aquathlon World Championships need to be entered through their National Federations.
  - d) The quota for any National Federation in any Paratriathlon category can be increased at the discretion of ITU.
  - e) The Paratriathlon categories are indicated in the ITU Competition Rules.

**6. DEADLINES:**

- 6.1. The National Federations must enter the athletes into the wait list via the ITU online entry system no less than 33 days before the first competition day.
- 6.2. 32 days before the first competition day, all the start lists will be published on [www.triathlon.org](http://www.triathlon.org)

**ITU Cross Triathlon World Championships  
QUALIFICATION CRITERIA**

**1. ELITE:**

- 1.1. National Federation quota for the ITU Elite Cross Triathlon World Championships in each of the men's and women's event:
- a) Maximum per National Federation is 6 athletes.
  - b) All qualified athletes for the ITU Elite Cross Triathlon World Championships need to be entered through their National Federations.
  - c) The quota for any National Federation can be increased at the discretion of ITU.

**2. UNDER23:**

- 2.1. National Federation quota for the ITU Elite Cross Triathlon U23 World Championships in each of the men's and women's event:
- a) Maximum per National Federation is 6 athletes.
  - b) All qualified athletes for the ITU Elite Cross Triathlon U23 World Championships need to be entered through their National Federations.
  - c) The quota for any National Federation can be increased at the discretion of ITU.

**3. JUNIOR:**

- 3.1. National Federation quota for the ITU Elite Cross Triathlon Junior World Championships in each of the men's and women's event:
- a) Maximum per National Federation is 6 athletes.
  - b) All qualified athletes for the ITU Elite Cross Triathlon Junior World Championships need to be entered through their National Federations.
  - c) The quota for any National Federation can be increased at the discretion of ITU.

**4. AGE-GROUPS:**

- 4.1. Qualification for the ITU Elite Cross Triathlon Age-Group World Championships will be:
- a) Every National Federation can enter 20 athletes in every age-group.
  - b) The host National Federation has a larger quota of 25 athletes in every age-group.
  - c) All qualified athletes for the ITU Elite Cross Triathlon Age-Group World Championships need to be entered through their National Federations.
  - d) The quota for any National Federation in any age-group can be increased at the discretion of ITU.
  - e) The age-group categories are indicated in the ITU Competition Rules.

**5. PARATRIATHLON:**

- 5.1. Qualification to the ITU Paratriathlon Elite Cross Triathlon World Championships will be:
- a) Every National Federation can enter 6 athletes in every Paratriathlon category.
  - b) The host National Federation has a larger quota of 8 athletes in every Paratriathlon category (except TRI 1)
  - c) All qualified athletes for the ITU Paratriathlon Elite Cross Triathlon World Championships need to be entered through their National Federations.
  - d) The quota for any National Federation in any Paratriathlon category can be increased at the discretion of ITU.
  - e) The Paratriathlon categories are indicated in the ITU Competition Rules.

**6. DEADLINES:**

- 6.1. The National Federations must enter the athletes into the wait list via the ITU online entry system no less than 33 days before the first competition day.
- 6.2. 32 days before the first competition day, all the start lists will be published on [www.triathlon.org](http://www.triathlon.org)

**ITU Duathlon World Championships  
QUALIFICATION CRITERIA**

**1. ELITE:**

- 1.1. National Federation quota for the ITU Elite Duathlon World Championships in each of the men's and women's event:
- a) Maximum per National Federation is 6 athletes.
  - b) All qualified athletes for the ITU Elite Duathlon World Championships need to be entered through their National Federations.
  - c) The quota for any National Federation can be increased at the discretion of ITU.

**2. UNDER23:**

- 2.1. National Federation quota for the ITU Elite Duathlon U23 World Championships in each of the men's and women's event:
- a) Maximum per National Federation is 6 athletes.
  - b) All qualified athletes for the ITU Elite Duathlon U23 World Championships need to be entered through their National Federations.
  - c) The quota for any National Federation can be increased at the discretion of ITU.

**3. JUNIOR:**

- 3.1. National Federation quota for the ITU Elite Duathlon Junior World Championships in each of the men's and women's event:
- a) Maximum per National Federation is 6 athletes.
  - b) All qualified athletes for the ITU Elite Duathlon Junior World Championships need to be entered through their National Federations.
  - c) The quota for any National Federation can be increased at the discretion of ITU.

**4. AGE-GROUPS:**

- 4.1. Qualification for the ITU Elite Duathlon Age-Group World Championships will be:
- a) Every National Federation can enter 20 athletes in every age-group.
  - b) The host National Federation has a larger quota of 25 athletes in every age-group.
  - c) All qualified athletes for the ITU Elite Duathlon Age-Group World Championships need to be entered through their National Federations.
  - d) The quota for any National Federation in any age-group can be increased at the discretion of ITU.
  - e) The age-group categories are indicated in the ITU Competition Rules.

**5. PARATRIATHLON:**

- 5.1. Qualification to the ITU Paratriathlon Elite Duathlon World Championships will be:
- a) Every National Federation can enter 6 athletes in every Paratriathlon category.
  - b) The host National Federation has a larger quota of 8 athletes in every Paratriathlon category.
  - c) All qualified athletes for the ITU Paratriathlon Elite Duathlon World Championships need to be entered through their National Federations.
  - d) The quota for any National Federation in any Paratriathlon category can be increased at the discretion of ITU.
  - e) The Paratriathlon categories are indicated in the ITU Competition Rules.

**6. DEADLINES:**

- 6.1. The National Federations must enter the athletes into the wait list via the ITU online entry system no less than 33 days before the first competition day.
- 6.2. 32 days before the first competition day, all the start lists will be published on [www.triathlon.org](http://www.triathlon.org)



**ITU Long Distance Duathlon World Championships  
QUALIFICATION CRITERIA**

**1. ELITE:**

- 1.1. National Federation quota for the ITU Elite Long Distance Duathlon World Championships in each of the men's and women's event:
- a) Maximum per National Federation is 6 athletes.
  - b) All qualified athletes for the ITU Elite Long Distance Duathlon World Championships need to be entered through their National Federations.
  - c) The quota of any National Federation can be increased at the discretion of ITU.

**2. AGE-GROUPS:**

- 2.1. Qualification for the ITU Long Distance Duathlon Age-Group World Championships will be:
- a) Every National Federation can enter 20 athletes in every age-group.
  - b) The host National Federation has a larger quota of 25 athletes in every age-group.
  - c) All qualified athletes for the ITU Long Distance Duathlon Age-Group World Championships need to be entered through their National Federations.
  - d) The quota for any National Federation in any age-group can be increased at the discretion of ITU.
  - e) The age-group categories are indicated in the ITU Competition Rules.

**3. PARATRIATHLON:**

- 3.1. Qualification to the ITU Paratriathlon Long Distance Duathlon World Championships will be:
- a) Every National Federation can enter 6 athletes in every Paratriathlon category.
  - b) The host National Federation has a larger quota of 8 athletes in every Paratriathlon category.
  - c) All qualified athletes for the ITU Paratriathlon Long Distance Duathlon World Championships need to be entered through their National Federations.
  - d) The quota for any National Federation in any Paratriathlon category can be increased at the discretion of ITU.
  - e) The Paratriathlon categories are indicated in the ITU Competition Rules.

**4. DEADLINES:**

- 4.1. The National Federations must enter the athletes into the wait list via the ITU online entry system no less than 90 days before the first competition day, for the Age Group athletes, and 33 days for Elite and Paratriathlon athletes.
- 4.2. One day after the deadline above indicated, the start lists will be published on [www.triathlon.org](http://www.triathlon.org)

**ITU Long Distance Triathlon World Championships  
QUALIFICATION CRITERIA**

**1. ELITE:**

- 1.1. National Federation quota for the ITU Elite Long Distance Triathlon World Championships in each of the men's and women's event:
- a) Maximum per National Federation is 6 athletes.
  - b) All qualified athletes for the ITU Elite Long Distance Triathlon World Championships need to be entered through their National Federations.
  - c) The quota for any National Federation can be increased at the discretion of ITU.

**2. AGE-GROUPS:**

- 2.1. Qualification for the ITU Long Distance Triathlon Age-Group World Championships will be:
- a) Every National Federation can enter 20 athletes in every age-group.
  - b) The host National Federation has a larger quota of 25 athletes in every age-group.
  - c) All qualified athletes for the ITU Long Distance Triathlon Age-Group World Championships need to be entered through their National Federations.
  - d) The quota for any National Federation in any age-group can be increased at the discretion of ITU.
  - e) The age-group categories are indicated in the ITU Competition Rules.

**3. PARATRIATHLON :**

- 3.1. Qualification to the ITU Paratriathlon Long Distance Triathlon World Championships will be:
- a) Every National Federation can enter 6 athletes in every Paratriathlon category.
  - b) The host National Federation has a larger quota of 8 athletes in every Paratriathlon category.
  - c) All qualified athletes for the ITU Paratriathlon Long Distance Triathlon World Championships to be entered through their National Federations.
  - d) The quota for any National Federation in any Paratriathlon category can be increased at the discretion of ITU.
  - e) The Paratriathlon categories are indicated in the ITU Competition Rules.

**4. DEADLINES:**

- 4.1. The National Federations must enter the athletes into the wait list via the ITU online entry system no less than 90 days before the first competition day, for the Age Group athletes, and 33 days for Elite and Paratriathlon athletes.
- 4.2. One day after the deadline above indicated, the start lists will be published on [www.triathlon.org](http://www.triathlon.org)

**ITU Winter Triathlon World Championships  
QUALIFICATION CRITERIA**

**1. ELITE:**

- 1.1. National Federation quota for the ITU Elite Winter Triathlon World Championships in each of the men's and women's event:
- a) Maximum per National Federation is 6 athletes.
  - b) All qualified athletes for the ITU Elite Winter Triathlon World Championships need to be entered through their National Federations.
  - c) The quota for any National Federation can be increased at the discretion of ITU.

**2. UNDER 23:**

- 2.1. National Federation quota for the ITU Winter Triathlon U23 World Championships in each of the men's and women's event:
- a) Maximum per National Federation is 6 athletes.
  - b) All qualified athletes for the ITU Winter Triathlon U23 World Championships need to be entered through their National Federations.
  - c) The quota for any National Federation can be increased at the discretion of ITU.

**3. JUNIOR:**

- 3.1. National Federation quota for the ITU Winter Triathlon Junior World Championships in each of the men's and women's event:
- a) Maximum per National Federation is 6 athletes.
  - b) All qualified athletes for the ITU Winter Triathlon Junior World Championships need to be entered through their National Federations.
  - c) The quota for any National Federation can be increased at the discretion of ITU.

**4. AGE-GROUPS:**

- 4.1. Qualification for the ITU Winter Triathlon Age-Group World Championships will be:
- a) Every National Federation can enter 20 athletes in every age-group.
  - b) The host National Federation has a larger quota of 25 athletes in every age-group.
  - c) All qualified athletes for the ITU Winter Triathlon Age-Group World Championships need to be entered through their National Federations.
  - d) The quota for any National Federation in any age-group can be increased at the discretion of ITU.
  - e) The age-group categories are indicated in the ITU Competition Rules.

**5. PARATRIATHLON:**

- 5.1. Qualification to the ITU Paratriathlon Elite Winter Triathlon World Championships will be:
- a) Every National Federation can enter 6 athletes in every Paratriathlon category. (except TRI 1)
  - b) The host National Federation has a larger quota of 8 athletes in every Paratriathlon category (except TRI 1)
  - c) All qualified athletes for the ITU Paratriathlon Elite Winter Triathlon World Championships need to be entered through their National Federations.
  - d) The quota for any National Federation in any Paratriathlon category can be increased at the discretion of ITU.
  - e) The Paratriathlon categories are indicated in the ITU Competition Rules.

**6. DEADLINES:**

- 6.1. The National Federations must enter the athletes into the wait list via the ITU online entry system no less than 33 days before the first competition day.
- 6.2. 32 days before the first competition day, all the start lists will be published on [www.triathlon.org](http://www.triathlon.org)

## ITU World Triathlon Series RANKING CRITERIA

### 1. PURPOSE:

- a) ITU World Triathlon Rankings will be used to determine the best performing triathletes of the season.
- b) The ITU World Champions will be established at the end of the series and the ITU World Triathlon Series Bonus Pool Prize Money will be distributed after the last scoring event according to the ITU World Championship Rankings.
- c) The ITU World Triathlon Series Rankings will become the first priority list to determine the eligible athletes for ITU World Triathlon Series Grand Final, ITU World Triathlon Series events and the ITU Triathlon World Cup events.

### 2. POINTS AND SCORING:

- a) **Scoring events:**
  - (i) There will be 3 levels of events included in the ITU World Championship Rankings:
    - The ITU World Triathlon Series Grand Final
    - The 2012 London Olympic Games
    - The ITU World Triathlon Series events
    - The ITU Triathlon World Cup events
  - (ii) The points earned by the best athlete for each event will be:
    - 1200 for the ITU World Championship Grand Final
    - 800 for the 2012 London Olympic Games
    - 800 for the ITU World Triathlon Series events
    - 300 for the ITU Triathlon World Cup events
  - (iii) The points table for each level of event will be from:
    - 1<sup>st</sup> to 50<sup>th</sup> for the ITU World Championship Grand Final
    - 1<sup>st</sup> to 40<sup>th</sup> for the 2012 London Olympic Games
    - 1<sup>st</sup> to 40<sup>th</sup> for the ITU World Triathlon Series events
    - 1<sup>st</sup> to 30<sup>th</sup> for the ITU Triathlon World Cup events
  - (iv) The points will be decreased according to points table below.
- b) **Cut off:** To earn points, athletes must finish within the cut-off time which will be determined by adding 5% to the winner's time in the men's event and 8% in the women's event.
- c) **Races scoring:** The final score will be obtained by adding the points gained in the ITU World Championship Grand Final plus the 5 best scores in the ITU World Triathlon Series events and the ITU Triathlon World Cup events with the following limitations:
  - (i) A maximum of 2 ITU Triathlon World Cup events scores will count for the final rankings.
- d) The intermediate rankings will be set as follows:

After the ITU WTS event number	Total events to add	Maximum ITU World Cups to count	ITU World Championship Grand Final
1	1	-	-
2	2	-	-
3	3	-	-
4	4	-	-
5	4	-	-
6	4	-	-
7	4	-	-
8	4	-	-
9	4	2	-
After Grand Final	5+Grand Final	2	1

- e) **Minimum ITU World Triathlon Series events to score:** Athletes must score points in a minimum of 2 ITU World Triathlon Series events to be eligible among the top 20 final rankings.
- f) **Season:** The ITU World Triathlon Series season starts immediately after the ITU World Triathlon Grand Final and finishes with the ITU World Triathlon Series Grand Final.

### 3. POINTS TABLE:

Finish Position	ITU World Triathlon Series Grand Final	ITU World Triathlon Series events	ITU Triathlon World Cup events
1	1200	800	300
2	1110	740	278
3	1027	685	257
4	950	633	237
5	879	586	220
6	813	542	203
7	752	501	188
8	695	464	174
9	643	429	161
10	595	397	149
11	550	367	138
12	509	339	127
13	471	314	118
14	436	290	109
15	403	269	101
16	373	248	93
17	345	230	86
18	319	213	80
19	295	197	74
20	273	182	68
21	252	168	63
22	233	156	58
23	216	144	54
24	200	133	50
25	185	123	46
26	171	114	43
27	158	105	40
28	146	97	37
29	135	90	34
30	125	83	31
31	116	77	-
32	107	71	-
33	99	66	-
34	92	61	-
35	85	56	-
36	78	52	-
37	72	48	-
38	67	44	-
39	62	41	-
40	57	38	-
41	53	-	-
42	49	-	-
43	45	-	-
44	42	-	-
45	39	-	-
46	36	-	-
47	33	-	-
48	30	-	-
49	28	-	-
50	26	-	-

### 4. Modified events:

- a) When a race cannot be held in the original form due to force majeure, the points will be reduced depending on the conditions on which finally the event took place:
- (i) If the event remains the same ITU multisport race, but any or all of the disciplines are shortened according to the ITU Competition Rules, 100% of the original points will be awarded.
  - (ii) If the event becomes another ITU multisport race according to the ITU Competition Rules in terms of distances and conditions, 75% of the original points will be awarded.
  - (iii) If the event becomes another ITU multisport race with deviations from the ITU Competition Rules in terms of distances and conditions, 50% of the original points will be awarded.

### ITU Points List Criteria

#### 1. PURPOSE:

- 1.1. ITU Points List will be used to determine athletes' eligibility to enter ITU Triathlon World Championship Series events, ITU Triathlon World Cup events, ITU Sprint Triathlon World Championships and ITU Triathlon Continental Championship events.
- 1.2. Continental Confederations may also use the ITU Points List to determine National Federation quotas for ITU Triathlon Continental Championships.
- 1.3. The ITU Points List will be posted on [www.triathlon.org](http://www.triathlon.org), but will not be considered as a ranking.

#### 2. ELIGIBILITY:

- 2.1. Only athletes in good standing with their National Federation affiliated with ITU are eligible to be included in the ITU Points List.

#### 3. SCORING EVENTS:

##### 3.1. General:

- a) There will be 7 levels of events included in the ITU Points List:
  - The ITU World Triathlon Series Grand Final
  - The ITU World Triathlon Series events
  - The ITU Triathlon World Cup events
  - The ITU Triathlon Continental Championships Standard Distance
  - The ITU Triathlon Continental Championships Sprint Distance<sup>3</sup>
  - The ITU Triathlon U23 World Championships
  - The ITU Triathlon Continental Cup and ITU Triathlon Premium Continental Cup events (these events can be either sprint or standard distance)
- b) The points earned by the best athlete for each event will be:
  - 1000 for the ITU World Triathlon Series Grand Final
  - 750 for the ITU World Triathlon Series events
  - 500 for the ITU Triathlon World Cup events
  - 400 for the ITU Triathlon Continental Championships Standard Distance
  - 300 for the ITU Triathlon Continental Championships Sprint Distance
  - 200 for the ITU Triathlon U23 World Championships
  - 200 for the ITU Triathlon Continental Cup and ITU Triathlon Premium Continental Cup events
- c) The points table for each level of event will be from:
  - 1<sup>st</sup> to 50<sup>th</sup> for the ITU World Triathlon Series Grand Final
  - 1<sup>st</sup> to 50<sup>th</sup> for the ITU World Triathlon Series events
  - 1<sup>st</sup> to 50<sup>th</sup> for the ITU Triathlon World Cup events
  - 1<sup>st</sup> to 50<sup>th</sup> for the ITU Triathlon Continental Championships Standard Distance (only athletes from the same continent)
  - 1<sup>st</sup> to 30<sup>th</sup> for the ITU Triathlon Continental Championships Sprint Distance (only athletes from the same continent)
  - 1<sup>st</sup> to 20<sup>th</sup> for the ITU Triathlon U23 World Championships
  - 1<sup>st</sup> to 20<sup>th</sup> for the ITU Triathlon Continental Cup and ITU Triathlon Premium Continental Cup events

---

<sup>3</sup> To be applied from Jan 1st 2013

- d) The points will be decreased by 7.5%. (i.e., if the winner of the ITU World Championship Grand Final gets 1000 points, the second will get 925, the third 855.62, the fourth 791.45, the fifth 732.09, etc.)
- 3.2. **Cut-off:** To earn points, athletes must finish within the cut-off time which will be determined by adding 5% to the winner's time in the men's event and 8% in the women's event.
- 3.3. **Quality of field:** Every athlete ranked in the top 20 of the current ITU Points list who starts the race will increase the value of the race by 2% up to a maximum of 20% per event.
- 3.4. **Total Events to Count:** The total number of points acquired by an athlete in a given year will be determined by adding the 6 best scores in the current year races, plus 1/3 of the points from the preceding year. An athlete may not earn points from more than 3 ITU Triathlon Continental Cup or ITU Triathlon Premium Continental Cup events.
- 3.5. **Removing from the ITU Points List:** Athletes with two complete calendar years without earning any point will be removed from the ITU Points List. This adjustment takes place every year on 1 January.

#### 4. Modified events:

- 4.1. When a race cannot be held in the original form due to force majeure, the points will be reduced depending on the conditions under which finally the event took place:
- If the event remains the same ITU multisport race, but any or all of the disciplines are shortened according to the ITU Competition Rules, 100% of the original points will be awarded.
  - If the event becomes another ITU multisport race according to the ITU Competition Rules in terms of distances and conditions, 75% of the original points will be awarded.
  - If the event becomes another ITU multisport race with deviations from the ITU Competition Rules in terms of distances and conditions, 50% of the original points will be awarded.



### ITU Continental Ranking Criteria

#### 1. GENERAL:

- 1.1. There are 5 Continental Rankings (one per continent: Africa, the Americas, Asia, Europe and Oceania).
- 1.2. The ITU Triathlon Continental Cup events may be categorised into two levels, according to system established by the Continental Confederation (i.e., difference in prize money, in television coverage, etc). The higher level ITU Triathlon Continental Cup events will be called "ITU Triathlon Premium Continental Cup" and the lower level "ITU Triathlon Continental Cup".
- 1.3. The title of the event will have the name of the continent replacing the word, "continent", i.e., 2010 Pontevedra ITU Triathlon Premium European Cup.

#### 2. ELIGIBILITY:

- 2.1. Only athletes in good standing with their National Federations affiliated with the Continental Confederation are eligible to be included in the ITU Continental Rankings from their continent.

#### 3. SCORING EVENTS:

##### 3.1. General:

- a) There will be 6 levels of events included in the ITU Points List:
  - The ITU Triathlon Continental Championships
  - The ITU Triathlon Continental Cup Final events
  - The ITU Triathlon Premium Continental Cup events
  - The ITU Triathlon Continental Cup events
  - The ITU Triathlon U23 Continental Championships
  - The Triathlon National Championships <sup>4</sup>
- b) The points earned by the best athlete for each event will be:
  - 600 for the ITU Triathlon Continental Championships
  - 500 for the ITU Triathlon Continental Cup Final events
  - 400 for the ITU Triathlon Premium Continental Cup events
  - 250 for the ITU Triathlon Continental Cup events
  - 250 for the ITU U23 Triathlon Continental Championships
  - 100 for the Triathlon National Championships
- c) The points table for each level of event will be from:
  - 1<sup>st</sup> to 40<sup>th</sup> for the ITU Triathlon Continental Championships
  - 1<sup>st</sup> to 30<sup>th</sup> for the ITU Continental Cup Final events
  - 1<sup>st</sup> to 20<sup>th</sup> for the ITU Triathlon Premium Continental Cup events
  - 1<sup>st</sup> to 20<sup>th</sup> for the ITU Triathlon Continental Cup events
  - 1<sup>st</sup> to 20<sup>th</sup> for the ITU Triathlon U23 Continental Championships
  - 1<sup>st</sup> to 5<sup>th</sup> for the Triathlon National Championships
- d) The points will be decreased by 7.5% (i.e., if the winner of the ITU Continental Championships gets 600 points, the second will get 555.00, the third 513.38, the fourth 474.87, etc.)

---

<sup>44</sup> National Federation can choose to include in the Continental Rankings either the standard or the sprint distance National Championships

- e) The events included in more than one level (i.e. National Championships taking place in a Continental Cup event) will give only one score to every athlete. If an athlete should gain points by more than one way (i.e. points for the overall event and points for the National Championships) only the highest score will be considered.
- 3.2. **Cut-off:** To earn points, athletes must finish within the cut-off time which will be determined by adding 5% to the winner's time in the men's event and 8% in the women's event.
- 3.3. **Quality of field:** Each athlete starting the race among the top 20 of the current ITU Continental Rankings will increase the value of the event by 2%. This increase is limited to 20%.
- 3.4. **Total Events to Count:**  
It will be a maximum of 10 events to count:
  - a) 5 from the 365 days previous to the date of the publication of the rankings (current period).
  - b) 5 from the days between the 366<sup>th</sup> and 730<sup>th</sup> previous to the date of publication of the rankings (previous period).
- 3.5. **Value of the points depending on the periods**
  - a) The value of the points in the current period is the same as those gained in the event.
  - b) The value of the points in the previous period is 1/3 of those gained in the event.

## 5. Modified events:

- a) When a race cannot be held in the original form due to force majeure, the points will be reduced depending on the conditions under which finally the event took place:
  - (i) If the event remains the same ITU multisport race, but any or all of the disciplines are shortened according to the ITU Competition Rules, 100% of the original points will be awarded.
  - (ii) If the event becomes another ITU multisport race according to the ITU Competition Rules in terms of distances and conditions, 75% of the original points will be awarded.
  - (iii) If the event becomes another ITU multisport race with deviations from the ITU Competition Rules in terms of distances and conditions, 50% of the original points will be awarded.

### ITU Duathlon Ranking Criteria

#### 1. PURPOSE:

- 1.1. ITU Duathlon Rankings will be used to determine the best performing duathletes of the season.

#### 2. POINTS AND SCORING:

##### 2.1. Scoring events:

- a) There will be 6 levels of events included in the ITU World Championship Rankings:
  - The ITU Duathlon World Championships
  - The ITU Long Distance Duathlon World Championships
  - The ITU Duathlon World Series events (Long and Standard Distances)
  - The ITU Duathlon Continental Championships events (Long and Standard Distances)
  - The Duathlon National Championships<sup>5</sup>
- b) The points earned by the best athlete for each event will be:
  - 1000 for the ITU Duathlon World Championships (Long and Standard Distances)
  - 600 for the ITU Duathlon Continental Championships (Long and Standard Distances)
  - 400 for the ITU Duathlon World Series events (Long and Standard Distances)
  - 150 for the Duathlon National Championships
- c) The points table for each level of event will be from:
  - 1<sup>st</sup> to 25<sup>th</sup> for the ITU Duathlon World Championships
  - 1<sup>st</sup> to 15<sup>th</sup> for the ITU Long Distance Duathlon World Championships
  - 1<sup>st</sup> to 15<sup>th</sup> for the ITU Duathlon World Series events
  - 1<sup>st</sup> to 15<sup>th</sup> for the ITU Duathlon Continental Championships
  - 1<sup>st</sup> to 10<sup>th</sup> for the ITU Duathlon Continental Cup events
  - 1<sup>st</sup> to 5<sup>th</sup> for the Duathlon National Championships
- d) The points will be decreased by 7.5% every position.
- e) The events included in more than one level (i.e. National Championships taking place in a Continental Cup event) will give only one score to every athlete. If an athlete should gain points by more than one way (i.e. points for the overall event and points for the National Championships) only the highest score will be considered.

- 2.2. **Total Events to Count:** The total number of points acquired by an athlete in a given year will be determined by adding the 4 best scores in the current year races.

- 2.3. **Removing from the ITU Duathlon Rankings:** Athletes will be removed every year from the ITU Duathlon Rankings on 1 January.

##### 2.4. Bonus Pool Prize Money:

- a) The ITU Duathlon Rankings winners will be established at the end of the series and the ITU Duathlon Rankings Bonus Pool Prize Money will be distributed after the last scoring event according to the ITU Duathlon Rankings.
- b) Athletes must score in a minimum of 3 events for ITU Duathlon Rankings in the same calendar year to be eligible for the Bonus Pool Prize Money.

---

<sup>5</sup> National Federation can choose to include in the Duathlon Rankings either the standard or the sprint distance National Championships

### 3. MODIFIED EVENTS:

- 3.1. When a race cannot be held in the original form due to force majeure, the points will be reduced depending on the conditions under which finally the event took place:
- a) If the event remains the same ITU multisport race, but any or all of the disciplines are shortened according to the ITU Competition Rules, 100% of the original points will be awarded.
  - b) If the event becomes another ITU multisport race according to the ITU Competition Rules in terms of distances and conditions, 75% of the original points will be awarded.
  - c) If the event becomes another ITU multisport race with deviations from the ITU Competition Rules in terms of distances and conditions, 50% of the original points will be awarded.

### ITU Long Distance Triathlon Ranking Criteria

#### 1. PURPOSE:

- 1.1. ITU Long Distance Triathlon Rankings will be used to determine the best performing long distance triathletes of the season.

#### 2. POINTS AND SCORING:

##### 2.1. Scoring events:

- a) There will be 5 levels of events included in the ITU World Championship Rankings:
  - The ITU Long Distance Triathlon World Championships
  - The ITU Long Distance Triathlon World Series events
  - The ITU Long Distance Triathlon Continental Championships
  - The ITU Long Distance Triathlon Continental Cup events
  - The Long Distance Triathlon National Championships
- b) The points earned by the best athlete for each event will be:
  - 750 for the ITU Long Distance Triathlon World Championships
  - 500 for the ITU Long Distance Triathlon World Series events
  - 500 for the ITU Long Distance Triathlon Continental Championships
  - 250 for the ITU Long Distance Triathlon Continental Cup events
  - 150 for the Long Distance Triathlon National Championships
- c) The points table for each level of event will be from:
  - 1<sup>st</sup> to 25<sup>th</sup> for the ITU Long Distance Triathlon World Championships
  - 1<sup>st</sup> to 15<sup>th</sup> for the ITU Long Distance Triathlon World Series events
  - 1<sup>st</sup> to 15<sup>th</sup> for the ITU Long Distance Triathlon Continental Championships
  - 1<sup>st</sup> to 10<sup>th</sup> for the ITU Long Distance Triathlon Continental Cup events
  - 1<sup>st</sup> to 5<sup>th</sup> for the Long Distance Triathlon National Championships
- d) The points will be decreased by 7.5% every position.
- e) The events included in more than one level (i.e. National Championships taking place in a Continental Cup event) will give only one score to every athlete. If an athlete should gain points by more than one way (i.e. points for the overall event and points for the National Championships) only the highest score will be considered.

- 2.2. **Total Events to Count:** The total number of points acquired by an athlete in a given year will be determined by adding the 4 best scores in the current year races.

- 2.3. **Removing from the ITU Long Distance Triathlon Rankings:** Athletes will be removed every year from the ITU Long Distance Triathlon Rankings on 1 January.

##### 2.4. Bonus Pool Prize Money:

- a) The ITU Long Distance Triathlon Rankings winners will be established at the end of the series and the ITU Long Distance Triathlon Rankings Bonus Pool Prize Money will be distributed after the last scoring event according to the ITU Long Distance Triathlon Rankings.
- b) Athletes must score in a minimum of 3 events for ITU Long Distance Triathlon Rankings in the same calendar year to be eligible for the Bonus Pool Prize Money.

### 3. **MODIFIED EVENTS:**

- 3.1. When a race cannot be held in the original form due to force majeure, the points will be reduced depending on the conditions under which finally the event took place:
- a) If the event remains the same ITU multisport race, but any or all of the disciplines are shortened according to the ITU Competition Rules, 100% of the original points will be awarded.
  - b) If the event becomes another ITU multisport race according to the ITU Competition Rules in terms of distances and conditions, 75% of the original points will be awarded.
  - c) If the event becomes another ITU multisport race with deviations from the ITU Competition Rules in terms of distances and conditions, 50% of the original points will be awarded.

### ITU Winter Triathlon Ranking Criteria

#### 1. PURPOSE:

- 1.1. ITU Winter Distance Triathlon Rankings will be used to determine the best performing winter triathletes of the season

#### 2. POINTS AND SCORING:

##### 2.1. Scoring events:

- a) There will be 5 levels of events included in the ITU World Championship Rankings:
  - The ITU Winter Triathlon World Championships
  - The ITU Winter Triathlon World Cup events
  - The ITU Winter Triathlon Continental Championships
  - The ITU Winter Triathlon Continental Cup events
  - The Winter Triathlon National Championships
- b) The points earned by the best athlete for each event will be:
  - 750 for the ITU Winter Triathlon World Championships
  - 500 for the ITU Winter Triathlon World Series events
  - 500 for the ITU Winter Triathlon Continental Championships
  - 250 for the ITU Winter Triathlon Continental Cup events
  - 150 for the Winter Triathlon National Championships
- c) The points table for each level of event will be from:
  - 1<sup>st</sup> to 25<sup>th</sup> for the ITU Winter Triathlon World Championships
  - 1<sup>st</sup> to 15<sup>th</sup> for the ITU Winter Triathlon World Series events
  - 1<sup>st</sup> to 15<sup>th</sup> for the ITU Winter Triathlon Continental Championships
  - 1<sup>st</sup> to 10<sup>th</sup> for the ITU Winter Triathlon Continental Cup events
  - 1<sup>st</sup> to 5<sup>th</sup> for the Winter Triathlon National Championships
- d) The points will be decreased by 7.5% every position.
- e) The events included in more than one level (i.e. National Championships taking place in a Continental Cup event) will give only one score to every athlete. If an athlete should gain points by more than one way (i.e. points for the overall event and points for the National Championships), only the highest score will be considered.

- 2.2. **Total Events to Count:** The total number of points acquired by an athlete in a given year will be determined by adding the 3 best scores in the current year races.

- 2.3. **Winter Season:** Winter season of a specific year will start on June 1<sup>st</sup> of the precedent year and will finish on May 31<sup>st</sup>. Athletes will be removed every year from the ITU Winter Distance Triathlon Rankings on May 31<sup>st</sup>.

#### 3. MODIFIED EVENTS:

- 3.1. When a race cannot be held in the original form due to force majeure, the points will be reduced depending on the conditions on which finally the event took place:
  - a) If the event remains the same ITU multisport race, but any or all of the disciplines are shortened according to the ITU Competition Rules, 100% of the original points will be awarded.
  - b) If the event becomes another ITU multisport race according to the ITU Competition Rules in terms of distances and conditions, 75% of the original points will be awarded.
  - c) If the event becomes another ITU multisport race with deviations from the ITU Competition Rules in terms of distances and conditions, 50% of the original points will be awarded.

### ITU Paratriathlon Ranking Criteria

#### 1. GENERAL

- 1.1. ITU Paratriathlon Rankings will be used to determine the best performing paratriathletes of the season.
- 1.2. There are 12 ITU Paratriathlon Rankings, one per Gender and Category: TRI1F, TRI1M, TRI2F, TRI2M, TRI3F, TRI3M, TRI4F, TRI4M, TRI5F, TRI5M, TRI6F and TRI6M.

#### 2. POINTS AND SCORING:

- 2.1. Scoring events:
  - a) There will be 4 levels of events included in the ITU Paratriathlon Rankings
    - The ITU Paratriathlon World Championships
    - The ITU Paratriathlon Continental Championships (\*)
    - The ITU sanctioned international Paratriathlon events
    - The Paratriathlon National Championships (\*\*)
  - b) The points earned by the best athlete for each event, category and gender will be:
    - 750 for the ITU Paratriathlon World Championships
    - 500 for the ITU Paratriathlon Continental Championships (\*)
    - 250 for the ITU sanctioned international Paratriathlon events
    - 150 for the Paratriathlon National Championships (\*\*)
  - c) The points table for each level of events will be from:
    - 1<sup>st</sup> to 10<sup>th</sup> for the ITU Paratriathlon World Championships
    - 1<sup>st</sup> to 5<sup>th</sup> for the ITU Paratriathlon Continental Championships (\*)
    - 1<sup>st</sup> to 5<sup>th</sup> for the ITU sanctioned international Paratriathlon events
    - 1<sup>st</sup> to 3<sup>rd</sup> for the Paratriathlon National Championships (\*\*)

(\*) Limited to the athletes from the respective continent.  
(\*\*) Limited to the athletes from the respective nation.

  - d) The points will be decreased by 7,5% every position
  - e) The events included in more than one level (i.e. National Championships taking place in an ITU International event) will give only one score to every athlete. If an athlete should gain points by more than one way (i.e. points for the overall event and points for the National Championships), only the highest score will be considered.
- 2.2. Total events to count: The total number of points acquired by an athlete in a given year will be determined by adding the 3 best scores earned in the current year races.



- 2.3. Cut-off: To earn points, athletes must finish within the cut-off time which will be determined by adding 40% to the race winner's time of the respective gender and category.
- 2.4. ITU Paratriathlon rankings will be cleared at January 1st of every year.

### **3. MODIFIED EVENTS:**

3.1. When a race cannot be held in the original format due to force majeure, the points will be reduced depending on the conditions under which finally the event took place:

- a) If the event remains as a triathlon, but any of all of the segments are shortened according to the ITU Competition Rules, 100 % of the points will be awarded.
- b) If the event becomes another ITU multisport race according to the ITU Competition Rules in terms of distances and conditions, 75 % of the points will be awarded.
- c) If the event becomes another ITU multisport race with deviations from the ITU Competition Rules in terms of distances and conditions, 50 % of the points will be awarded.

## 26. APPENDIX F1

### ELITE UNDER23 AND JUNIOR UNIFORM RULES

#### 1. Overview:

- 1.1. To compete in ITU events, athletes must comply with the ITU Uniform Rules.
- 1.2. The images on this document are reproducing a typical triathlon uniform. For winter triathlon and in some cases in triathlon, duathlon and aquathlon, the long sleeves and pants are allowed. This rule applies in the same way for all the cases.

#### 2. Purpose:

- 2.1. Provide a clean and professional image of our sport to local and global spectators and media.
- 2.2. Provide sponsors with reasonable space for viable exposure.
- 2.3. Provide a framework for enabling ITU member National Federations (NFs) and athletes to have a mutually beneficial relationship with respect to rights and responsibilities, as per Appendix F.2.

#### 3. General Requirements:

- 3.1. Uniforms will be completely clean of any logos or images other than those described below.
- 3.2. Logos will be measured on a flat surface when the athlete is not wearing the uniform. The "ITU Logo Measurement Template" will be used to measure the logo sizes.
- 3.3. There is no restriction on the type of logo used in the sponsor spaces other than those representing tobacco, spirits and products containing any substance on the WADA Prohibited List.
- 3.4. There must be a minimum clearance space of 1.5cm around all marks including:
  - a) The ITU logo;
  - b) The family name
  - c) The country code;
  - d) All sponsor logos

#### 4. Uniform Colour and Design:

- 4.1. Uniforms must be in the colours chosen by the National Federation (NF) for ITU World Triathlon Series Grand Final, ITU World Triathlon Series, ITU Continental Championships and ITU Multisport World Championships events. For all other ITU events the uniform colors have no restrictions.
- 4.2. The colour and design of the uniform and podium apparel must be distinct to that country and must be approved by ITU in advance.
- 4.3. Country uniforms must have a distinct look, however the design requirements should not impact on technical requirements athletes might have due to body shape or size.
- 4.4. The approval process for the uniform colour and design is outlined in Appendix F.8. The goal of the approval process is to ensure countries do not have the same uniform colour and design.

- 4.5. ITU reserves the right to establish a specific rule till 30th of January 2011 regarding the color of the uniform of the actual leader of ITU World Triathlon Series has to wear.



## 5. Family Name and Country Code/Name:

- 5.1. The family name and the IOC country code must be placed on the upper front of the uniform and also on the buttocks. The representation of both the family name and country code must meet the following criteria:

a) **Font Type:**

- The font type must be "Arial".
- Letters for the family name and country code must be in upper case, unless the name is more than 9 letters, in which case lower case letters should be used following the first capital letter. (See Diagram 2: Family Name Layout).

b) **Colour:**

- If the uniform is a dark colour, the letters must be white. If the uniform is a light colour, the letters must be black.

c) **Position:**

- Front: The position on the front is below the ITU logo and Sponsor Spaces B and F. The athlete's family name is above the country code and Sponsor Space A.
- Back: The position on the back is below the waistline so that it is clearly visible when the athlete is on the bike.
- Height: The family name and the country code must be 5cm in height, regardless of the number of letters in the name.
- Width: The length for the family name is a minimum of 12cm and a maximum of 15cm. A family name with few letters must still be a minimum length of 12 cm. (See Diagram 2: Family Name Layout) The width for the country code must be 8cm in length.

**Diagram 2. Family Name Layout**

MAY

- For family names such as “MAY” above, the height is 5cm and the width is 12cm.
- For longer names such as “Polikarpenko” below, the height is still a minimum 5cm but the name should take up the full 15cm.

Polikarpenko

## 6. ITU Logo:

- 6.1. The official ITU logo will appear on the upper **right** shoulder.
- 6.2. It will conform to the official ITU rings with the letters ITU on the bottom right.
- 6.3. The horizontal dimension will be 4cm.
- 6.4. The white version should be applied to dark coloured uniforms, the blue and orange version should be applied to light coloured uniforms (see 6.5, 6.6, Diagram 3).
- 6.5. Click [here](#) for the print version of the ITU logo.

**Diagram 3. ITU Logo Layout**



- 6.6. Diagram 3 above shows the correct layout for the ITU Logo.
  - a) ITU Orange:
    - Pantone 144C (Coated papers)
    - CMYK conversion (four-colour process) - C: 0%, M: 49%, Y: 100%, K: 0%
  - b) ITU Blue

- Pantone 2955C (Coated papers)
- CMYK conversion (four-colour process) - C: 100%, M: 45%, Y: 0%, K: 37%

## 7. Sponsor Spaces:

### 7.1. Sponsor Space A:

- This space is directly below the country code (See Diagram 1. Sponsor Logos: size and space).
- The maximum height is 20cm.
- The maximum length is 15cm.
- Up to 3 sponsor logos may be positioned in this space.
- The athlete may have 1, 2 or 3 logos in this space. Each of the logos must represent a different sponsor.

### 7.2. Sponsor Space B: upper left front:

- This space is for the manufacturer of the uniform or for another sponsor.
- The maximum height is 4cm.
- The maximum length is 5cm.
- The space must be on the left hand shoulder of the uniform – not the middle.

### 7.3. Sponsor Spaces C: side panels:

- Sponsor logos may appear on the side panel.
- The maximum width is 5cm.
- The maximum length 15cm.
- Only one sponsor logo is allowed on each side and it must be the same sponsor logo.
- This space must be visible from the side of the body. If, due to the athlete body, this space is partly visible from the front, it has to be visible also from the back.

### 7.4. Sponsor Space D: lower front:

- The maximum height is 4cm.
- The maximum length is 5cm.
- This space can be on the lower left or right side of the uniform but not both.

### 7.5. Sponsor Space E: upper back:

- One logo of any sponsor may appear above the family name on the back.
- The maximum height is 10cm.
- The maximum length is 15cm.

### 7.6. Sponsor Space F: upper front:

- One logo of any sponsor may appear above the family name on the front.
- The maximum height is 5cm.
- The maximum length is 15cm.

## 8. Headwear:

### 8.1. Swim:

- No sponsor logos are allowed on the swim cap other than as prescribed by ITU/LOC

## 8.2. Cycle:

- a) Athletes must wear helmets on the bicycle segment, as described by the ITU Competition Rules.
- b) Helmet race number stickers, provided by ITU or the LOC, must be placed on the front and both sides of the helmet, without any alteration. No other stickers are allowed.
- c) There must be a clearance around the official helmet number sticker of 1.5cm to ensure the number is clearly visible.
- d) The helmet manufacturer's logo may appear on the helmet, either by one 30cm<sup>2</sup> location on the front, or one 20cm<sup>2</sup> on each side. No other sponsor logo may appear on the helmet, and to cover these unacceptable logos with stickers is not allowed.
- e) The helmet can be in any colour.

## 8.3. Run:

- a) Athletes may wear hats or visors on the run section.
- b) Only 1 sponsor logo can be placed on the hat or visor.
- c) The maximum height is 4cm.
- d) The maximum total area is 20cm<sup>2</sup>.

## 9. Wetsuits:

9.1. **Model Approval:** All wetsuit models must have prior written approval from ITU.

### 9.2. Logos:

- a) Only the wetsuit manufacturer's logo may appear on the wetsuits.
- b) The maximum size is 80cm<sup>2</sup> on the front and back. This space is allowed both on the inside and outside of the wetsuit.
- c) If the manufacturer wishes to have two or more logos on the front or back, the combined total must not exceed 80cm<sup>2</sup>.
- d) Logos on the side panel must be included within either the 80cm<sup>2</sup> for the back or the 80cm<sup>2</sup> for the front.

## 10. Race Numbers:

10.1. **Traditional race numbers:** will not be used for elite athletes in ITU Triathlon and Multisport World Championships (excluding Winter Triathlon) or World Cup Events.

### 10.2. Body Decals:

- a) ITU will provide body number decals and each elite athlete will apply them prior to the event.
- b) One set of body number decals are to be applied to each arm and each leg.
- c) For double digit numbers, decals must be applied one above the other, not side by side.

For example the number 23 should appear like this **2** Not like this... **23**  
**3**

## 11. Temporary Tattoos:

11.1. Athletes are not allowed to place any temporary tattoo, other than the race numbers provided by ITU, on their body during ITU events.

## 12. Podium apparel.

12.1. All the sponsor spaces and design colors indicated in this appendix, apply as well to the podium apparel.

### APPENDIX F2: RIGHTS AND RESPONSIBILITIES (Elite, U23 and Junior athletes)

	Other ITU Events	Multisport Championships	Continental Cup Events	Continental Championships	Triathlon World Cup Events	World Triathlon Series incl. Grand Final
Uniform Colour and Design	Yes	No	Yes	No	Yes	No
Family Name	No	No	No	No	No	No
Country Code / Name	No	No	No	No	No	No
ITU Logo	No	No	No	No	No	No
Sponsorship A	Yes	Yes	Yes	Yes	Yes	Yes
Sponsorship B	Yes	Yes	Yes	Yes	Yes	Yes
Sponsorship C	Yes	Yes	Yes	Yes	Yes	Yes
Sponsorship D	Yes	Yes	Yes	Yes	Yes	Yes
Sponsorship E	Yes	Yes	Yes	Yes	Yes	Yes
Sponsorship F	Yes	Yes	Yes	Yes	Yes	Yes

#### Legend:

- **No**: There is no negotiation on these areas. Must be as outlined in the ITU Uniform Rules.
- **Yes**: Negotiate in good faith.

## **F3 PARATRIATHLON UNIFORM RULES**

### **1. Overview:**

- 1.1. To compete in ITU events, athletes must comply with the ITU Uniform Rules.
- 1.2. The images in this document are intended to show a typical triathlon uniform. For winter triathlon, and in some cases in triathlon, duathlon and aquathlon, long sleeves and pants are allowed. This rule applies in the same way in all cases.

### **2. Purpose:**

- 2.1. Provide a clean and professional image of our sport to local and global spectators and media.
- 2.2. Provide sponsors with reasonable space for viable exposure.
- 2.3. Provide a framework for ITU member National Federations (NFs) and athletes to enable both parties to have a mutually beneficial relationship with respect to rights and responsibilities, as per Appendix F.4

### **3. General Requirements:**

- 3.1. Uniforms will be completely clean of any logos or images other than those described below.
- 3.2. Logos will be measured on a flat surface when the athlete is not wearing the uniform. The "ITU Logo Measurement Template" will be used to measure the logo sizes.
- 3.3. There is no restriction on the type of logo used in the sponsor spaces other than those representing tobacco, spirits and products containing any substance on the WADA Prohibited List. (See Diagram 1 for location of sponsor spaces).
- 3.4. There must be a minimum clearance space of 1.5cm around all marks including:
  - a) The ITU logo;
  - b) The family name;
  - c) The country code;
  - d) All sponsor spaces

### **4. Uniform Colour and Design:**

- 4.1. Uniforms must be in the colours chosen by the National Federation (NF) for ITU World Championship Grand Final, ITU Continental Championships and ITU Multisport World Championships events.
- 4.2. The colour and design of the uniform and podium apparel must be distinct to that country and must be approved by ITU in advance.
- 4.3. It is intended to give the country uniforms a distinct look. However the design definition should not impact on technical requirements that athletes might have due to body shape or size.
- 4.4. The approval process for the uniform colour and design is outlined in Appendix F.8. The goal of the approval process is to ensure different countries do not have the same uniform colour and design.



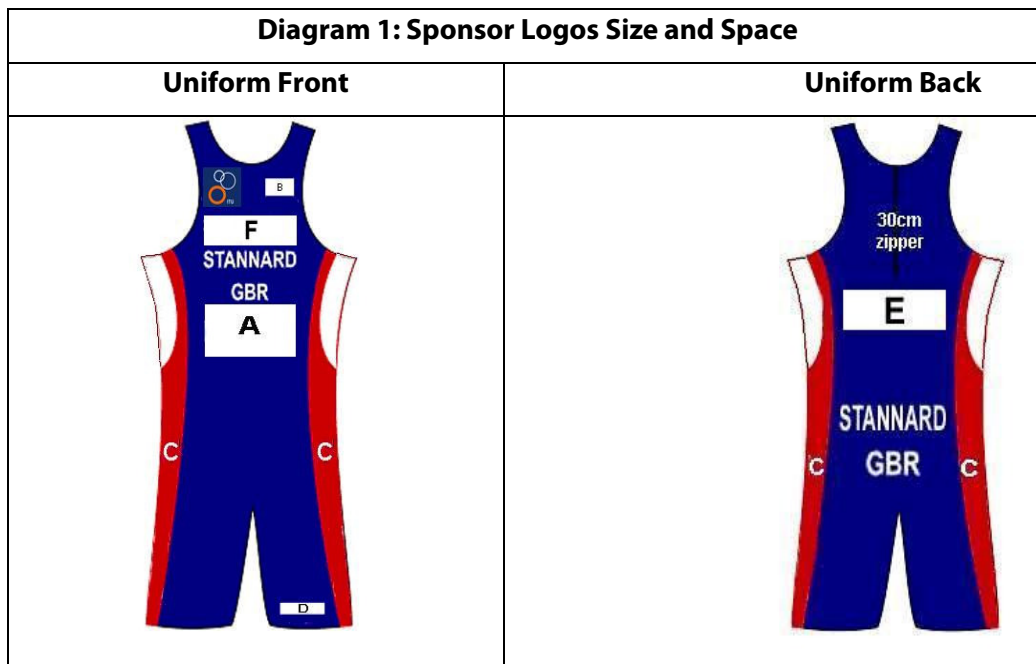

## 5. Family Name and Country Code:

5.1. The IOC country code must be placed on the upper front of the uniform and also on the buttocks. The placement of the family name on the upper front and on the buttock of the uniform is optional for Age Group athletes. The representation of both the family name and country code must meet the following criteria:

a) **Font Type:**

- The font type must be “Arial”.
- Letters for the family name and country code must be in upper case, unless the name is more than 9 letters, in which case lower case letters should be used following the first capital letter. (See Diagram 2: Family Name Layout).

b) **Colour:**

- If the uniform is a dark colour, the letters must be white. If the uniform is a light colour, the letters must be black.

c) **Position:**

- Front: The position on the front is below the ITU logo and Sponsor Spaces B and F. The athlete’s family name is above the country code and Sponsor Space A.
- Back: The position on the back is below the waistline so that it is clearly visible when the athlete is on the bike.
- Height: The family name and the country code must be a 5cm in height, regardless of the number of letters in the name.
- Width: The length for the family name is a minimum of 12cm and a maximum of 15cm. A family name with few letters must still be a minimum length of 12 cm. (See Diagram 2: Family Name Layout) The width for the country code must be 8cm in length.

**Diagram 2. Family Name Layout**

**MAY**

- For family names such as “MAY” above, the height is 5cm and the width is 12cm.
- For longer names such as “Polikarpenko” below, the height is still a minimum 5cm but the name should take up the full 15cm.

**Polikarpenko**

**6. ITU Logo:**

- 6.1. The official ITU logo will appear on the upper **right** shoulder.
- 6.2. It will conform to the official ITU rings with the letters ITU on the bottom right.
- 6.3. The horizontal dimension will be 4cm.
- 6.4. The white version should be applied to dark coloured uniforms, the blue and orange version should be applied to light coloured uniforms (see 6.5, 6.6, Diagram 3).
- 6.5. Click [here](#) for the print version of the ITU logo.

**Diagram 3. ITU Logo Layout**



→  
**4 cm**

- 6.6. Diagram 3 above shows the correct layout for the ITU Logo.
  - a) ITU Orange:
    - Pantone 144C (Coated papers)
    - CMYK conversion (four-colour process) - C: 0%, M: 49%, Y: 100%, K: 0%
  - b) ITU Blue
    - Pantone 2955C (Coated papers)
    - CMYK conversion (four-colour process) - C: 100%, M: 45%, Y: 0%, K: 37%

## 7. Sponsor Spaces:

### 7.1. Sponsor Space A:

- a) This space is directly below the country code (See Diagram 1. Sponsor Logos: size and space).
- b) The maximum height is 20cm.
- c) The maximum length is 15cm.
- d) Up to 3 sponsor logos may be positioned in this space.
- e) The athlete may have 1, 2 or 3 logos in this space. Each of the logos must represent a different sponsor.

### 7.2. Sponsor Space B: upper left front:

- a) This space is for the manufacturer of the uniform or for another sponsor.
- b) The maximum height is 4cm.
- c) The maximum length is 5cm.
- d) The space must be on the left hand shoulder of the uniform – not the middle.

### 7.3. Sponsor Spaces C: side panels:

- a) Sponsor logos may appear on the side panel.
- b) The maximum width is 5cm.
- c) The maximum length 15cm.
- d) Only one sponsor logo is allowed on each side and it must be the same sponsor logo.
- e) This space must be visible from the side of the body. If, due to the athlete body, this space is partly visible from the front, it has to be visible also from the back.

### 7.4. Sponsor Space D: lower front:

- a) The maximum height is 4cm.
- b) The maximum length is 5cm.
- c) This space can be on the lower left or right side of the uniform but not both.

### 7.5. Sponsor Space E: upper back:

- a) One logo of any sponsor may appear above the family name on the back.
- b) The maximum height is 10cm.
- c) The maximum length is 15cm.

### 7.6. Sponsor Space F: upper front:

- a) One logo of any sponsor may appear above the family name on the front.
- b) The maximum height is 5cm.
- c) The maximum length is 15cm.

## 8. Headwear:

### 8.1. Swim:

- a) No sponsor logos are allowed on the swim cap other than as prescribed by the ITU / LOC.

## 8.2. Cycle:

- a) Athletes must wear helmets on the bicycle section, as described by the ITU Competition Rules.
- b) Helmet race number stickers, provided by ITU or the LOC, must be placed on the front and both sides of the helmet, without any alteration. No other stickers are allowed.
- c) There must be a clearance around the official helmet number sticker of 1.5cm to ensure the number is clearly visible.
- d) The helmet manufacturer's logo may appear on the helmet, either by one 30cm<sup>2</sup> location on the front, or one 20cm<sup>2</sup> on each side. No other sponsor logo may appear on the helmet, and to cover these unacceptable logos with stickers is not allowed.
- e) The helmet can be in any colour.

## 8.3. Run:

- a) Athletes may wear hats or visors on the run section.
- b) Only 1 sponsor logo can be placed on the hat or visor.
- c) The maximum height is 4cm.
- d) The maximum total area is 20cm<sup>2</sup>.

## 9. Bicycle:

- a) Only logos of bicycle related products may appear on the athlete's bicycle.
- b) Logos may not interfere with, or hinder the placement of, the bicycle race number on the bicycle frame.
- c) Bike race number stickers, provided by ITU or the LOC, must be placed on the bike as instructed, without any alteration.

## 10. Wetsuits:

10.1. **Model Approval:** All wetsuit models must have prior written approval from ITU.

### 10.2. Logos:

- a) Only the wetsuit manufacturer's logo may appear on the wetsuits.
- b) The maximum size is 80cm<sup>2</sup> on the front and back. This space is allowed both on the inside and outside of the wetsuit.
- c) If the manufacturer wishes to have two or more logos on the front or back, the combined total must not exceed 80cm<sup>2</sup>.
- d) Logos on the side panel must be included within either the 80cm<sup>2</sup> for the back or the 80cm<sup>2</sup> for the front.

## 11. Race Numbers:

11.1. **Traditional race numbers:** Race numbers, provided by ITU or the LOC, must be worn as instructed by the ITU Technical Delegate on the Athletes' or Team Managers' Briefing, without any alteration.

### 11.2. **Body Marking:**

- a) LOC will provide body marking and each elite athlete will apply them prior to the event.
- b) One set of body marking are to be applied to each arm and each leg unless instructed by the ITU Technical Delegate on the Athletes' or Team Managers' Briefing.

### 12. **Temporary Tattoos:**

- 12.1. Athletes are not allowed to place any temporary tattoo.

### 13. **Specific Rules for TRI6 Category:**

- 13.1. The uniform of the Guide of the TRI6 athlete must comply with the rules above and use the same sponsors' logos and spaces as on the TRI6 athlete's uniform.
- 13.2. At the Family Name space, the uniform of the Guide must have the word "GUIDE".
- 13.3. The font type must be "Arial", the height 5cm and the width 12 cm.

**APPENDIX F4: RIGHTS AND RESPONSIBILITIES (Paratriathlon athletes)**

	Triathlon World Championships	Multisport Championships	Other ITU events
Uniform Colour and Design	No	No	Yes
Family Name	No	No	No
Country Code / Name	No	No	No
ITU Logo	No	No	No
Sponsorship A	Yes	Yes	Yes
Sponsorship B	Yes	Yes	Yes
Sponsorship C	Yes	Yes	Yes
Sponsorship D	Yes	Yes	Yes
Sponsorship E	Yes	Yes	Yes
Sponsorship F	Yes	Yes	Yes

**Legend:**

- **No:** There is no negotiation on these areas. Must be as outlined in the ITU Uniform Rules.
- **Yes:** Negotiate in good faith.

## **F5 AGE GROUP UNIFORM RULES**

### **1. Overview:**

- 1.1. To compete in ITU events, athletes must comply with the ITU Uniform Rules.
- 1.2. The images in this document are intended to show a typical triathlon uniform. For winter triathlon, and in some cases in triathlon, duathlon and aquathlon, long sleeves and pants are allowed. This rule applies in the same way in all cases.

### **2. Purpose:**

- 2.1. Provide a clean and professional image of our sport to local and global spectators and media.
- 2.2. Provide sponsors with reasonable space for viable exposure.
- 2.3. Provide a framework enabling ITU member National Federations (NFs) and athletes to have a mutually beneficial relationship with respect to rights and responsibilities, as per Appendix F.6.

### **3. General Requirements:**

- 3.1. Uniforms will be completely clean of any logos or images other than those described below.
- 3.2. Logos will be measured on a flat surface when the athlete is not wearing the uniform. The "ITU Logo Measurement Template" will be used to measure the logo sizes.
- 3.3. There is no restriction on the type of logo used in the sponsor spaces other than those representing tobacco, spirits and products containing any substance on the WADA Prohibited List. (See Diagram 1 for location of sponsor spaces).
- 3.4. There must be a minimum clearance space of 1.5cm around all marks including:
  - a) The ITU logo;
  - b) The family name;
  - c) The country code;
  - d) All sponsor spaces

### **4. Uniform Colour and Design:**

- 4.1. Uniforms must be in the colours chosen by the National Federation (NF) for ITU World Championship Grand Final, ITU Continental Championships and ITU Multisport World Championships events.
- 4.2. The colour and design of the uniform and podium apparel must be distinct to that country and must be approved by ITU in advance.
- 4.3. Country uniforms must have a distinct look, however the design requirements should not impact on technical requirements athletes might have due to body shape or size.
- 4.4. The approval process for the uniform colour and design is outlined in Appendix F.8. The goal of the approval process is to ensure different countries do not have the same uniform colour and design.

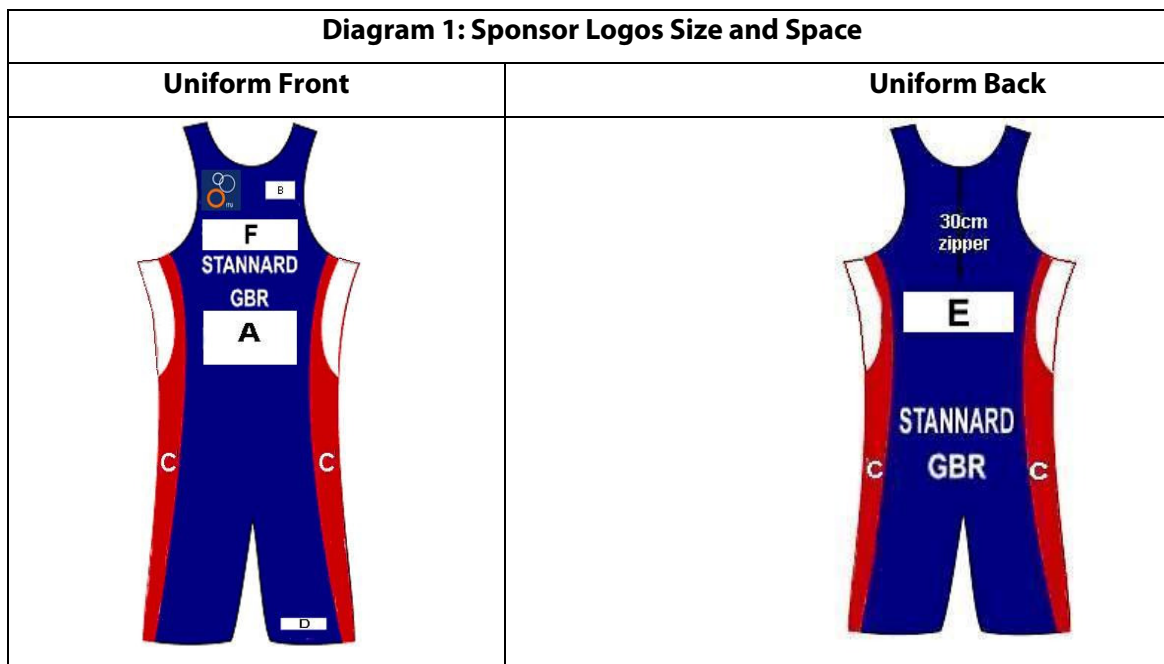

## 5. Family Name and Country Code:

5.1. The IOC country code must be placed on the upper front of the uniform and also on the buttocks. The placement of the family name on the upper front and on the buttock of the uniform is optional for Age Group athletes. The representation of both the family name and country code must meet the following criteria:

a) **Font Type:**

- The font type must be "Arial".
- Letters for the family name and country code must be in upper case, unless the name is more than 9 letters, in which case lower case letters should be used following the first capital letter. (See Diagram 2: Family Name Layout).

b) **Colour:**

- If the uniform is a dark colour, the letters must be white. If the uniform is a light colour, the letters must be black.

c) **Position:**

- Front: The position on the front is below the ITU logo and Sponsor Spaces B and F. The athlete's family name is above the country code and Sponsor Space A.
- Back: The position on the back is below the waistline so that it is clearly visible when the athlete is on the bike.
- Height: The family name and the country code must be a 5cm in height, regardless of the number of letters in the name.
- Width: The length for the family name is a minimum of 12cm and a maximum of 15cm. A family name with few letters must still be a minimum length of 12 cm. (See Diagram 2: Family Name Layout) The width for the country code must be 8cm in length.



**Diagram 2. Family Name Layout**

MAY

- For family names such as “MAY” above, the height is 5cm and the width is 12cm.
- For longer names such as “Polikarpenko” below, the height is still a minimum 5cm but the name should take up the full 15cm.

Polikarpenko

## 6. ITU Logo:

- 6.1. The official ITU logo will appear on the upper **right** shoulder.
- 6.2. It will conform to the official ITU rings with the letters ITU on the bottom right.
- 6.3. The horizontal dimension will be 4cm.
- 6.4. The white version should be applied to dark coloured uniforms, the blue and orange version should be applied to light coloured uniforms (see 6.5, 6.6, Diagram 3).
- 6.5. Click [here](#) for the print version of the ITU logo.

**Diagram 3. ITU Logo Layout**



- 6.6. Diagram 3 above shows the correct layout for the ITU Logo.
  - a) ITU Orange:
    - Pantone 144C (Coated papers)
    - CMYK conversion (four-colour process) - C: 0%, M: 49%, Y: 100%, K: 0%
  - b) ITU Blue
    - Pantone 2955C (Coated papers)
    - CMYK conversion (four-colour process) - C: 100%, M: 45%, Y: 0%, K: 37%

## 7. Sponsor Spaces:

### 7.1. Sponsor Space A:

- a) This space is directly below the country code (See Diagram 1. Sponsor Logos: size and space).
- b) The maximum height is 20cm.
- c) The maximum length is 15cm.
- d) Up to 3 sponsor logos may be positioned in this space.
- e) The athlete may have 1, 2 or 3 logos in this space. Each of the logos must represent a different sponsor.

### 7.2. Sponsor Space B: upper left front:

- a) This space is for the manufacturer of the uniform or for another sponsor.
- b) The maximum height is 4cm.
- c) The maximum length is 5cm.
- d) The space must be on the left hand shoulder of the uniform – not the middle.

### 7.3. Sponsor Spaces C: side panels:

- a) Sponsor logos may appear on the side panel.
- b) The maximum width is 5cm.
- c) The maximum length 15cm.
- d) Only one sponsor logo is allowed on each side and it must be the same sponsor logo.
- e) This space must be visible from the side of the body. If, due to the athlete body, this space is partly visible from the front, it has to be visible also from the back.

### 7.4. Sponsor Space D: lower front:

- a) The maximum height is 4cm.
- b) The maximum length is 5cm.
- c) This space can be on the lower left or right side of the uniform but not both.

### 7.5. Sponsor Space E: upper back:

- a) One logo of any sponsor may appear above the family name on the back.
- b) The maximum height is 10cm.
- c) The maximum length is 15cm.

### 7.6. Sponsor Space F: upper front:

- a) One logo of any sponsor may appear above family name and/or the country code on the front.
- b) The maximum height is 5cm.
- c) The maximum length is 15cm.

## 8. Headwear:

### 8.1. Swim:

- a) No sponsor logos are allowed on the swim cap other than as prescribed by the ITU / LOC.

## 8.2. Cycle:

- a) Athletes must wear helmets on the bicycle section, as described by the ITU Competition Rules.
- b) Helmet race number stickers, provided by ITU or the LOC, must be placed on the front and both sides of the helmet, without any alteration. No other stickers are allowed.
- c) There must be a clearance around the official helmet number sticker of 1.5cm to ensure the number is clearly visible.
- d) The helmet manufacturer's logo may appear on the helmet, either by one 30cm<sup>2</sup> location on the front, or one 20cm<sup>2</sup> on each side. No other sponsor logo may appear on the helmet, and to cover these unacceptable logos with stickers is not allowed.
- e) The helmet can be in any colour.

## 8.3. Run:

- a) Athletes may wear hats or visors on the run section.
- b) Only 1 sponsor logo can be placed on the hat or visor.
- c) The maximum height is 4cm.
- d) The maximum total area is 20cm<sup>2</sup>.

## 9. Wetsuits:

9.1. **Model Approval:** All wetsuit models must have prior written approval from ITU.

### 9.2. Logos:

- a) Only the wetsuit manufacturer's logo may appear on the wetsuits.
- b) The maximum size is 80cm<sup>2</sup> on the front and back. This space is allowed both on the inside and outside of the wetsuit.
- c) If the manufacturer wishes to have two or more logos on the front or back, the combined total must not exceed 80cm<sup>2</sup>.
- d) Logos on the side panel must be included within either the 80cm<sup>2</sup> for the back or the 80cm<sup>2</sup> for the front.

## 10. Race Numbers:

10.1. **Traditional race numbers:** Race numbers, provided by ITU or the LOC, must be worn as instructed by the ITU Technical Delegate on the Athletes' or Team Managers' Briefing, without any alteration.

### 10.2. Body Marking:

- a) LOC will provide body marking and each elite athlete will apply them prior to the event.
- b) One set of body marking are to be applied to each arm and each leg unless instructed by the ITU Technical Delegate on the Athletes' or Team Managers' Briefing.
- c) One calf of the athletes must be marked with the category and the gender of the athletes. (For example the number M25 should appear for men athletes in the category men 25-29 or the number F40 should appear for the women athletes in category women 40-44.)

## 11. Temporary Tattoos:

11.1. Athletes are not allowed to place any temporary tattoo.

**APPENDIX F6: RIGHTS AND RESPONSIBILITIES (Age Group athletes)**

	Triathlo World Championships	Multisport Championships	Other ITU events
Uniform Colour and Design	No	No	Yes
Family Name	No	No	No
Country Code / Name	No	No	No
ITU Logo	No	No	No
Sponsorship A	Yes	Yes	Yes
Sponsorship B	Yes	Yes	Yes
Sponsorship C	Yes	Yes	Yes
Sponsorship D	Yes	Yes	Yes
Sponsorship E	Yes	Yes	Yes
Sponsorship F	Yes	Yes	Yes

**Legend:**

- **No:** There is no negotiation on these areas. Must be as outlined in the ITU Uniform Rules.
- **Yes:** Negotiate in good faith.

## F7 ITU COMPETITION UNIFORM APPROVAL PROCESS

### 1. Overview:

1.1 This process is part of the ITU Uniform Rules and is a specific addition to the ITU Competition Rules.

### 2. Purpose:

2.1 The process was created to regulate the ITU's approval of the design of each NF's competition uniform to be used by their athletes in all ITU competitions according with the ITU Uniform Rules.

### 3. General Requirements:

3.1 Every NF uniform has to be different from any other NF uniform, according to the ITU Uniform Rules. The difference will be significant to avoid confusion between two different NFs.

3.2 Artistic or creative elements are acceptable provided the ITU Competition Rules are followed. Specifically, if the design contains recognisable commercial logos or trade marks which exceed the surface limits, it will not be approved.

3.3 The same design applies to all types of uniforms: men, women, triathlon style, duathlon style, summer, winter, etc.

3.4 Every NF can request the approval of a different uniform design for every different multisport, and two different uniforms for triathlon, indicating which is the 1st option and which is the 2nd option. However, all athletes from the same NF, competing in the same event, will wear the NF's same distinctive design.

### 4. Timeline for Approval:

4.1 NFs will submit a proposed design of their Competition Uniform for the following year, according to these specifications:

- a) A pattern provided by ITU will be used, (see Diagram 1, ITU Competition Rules.)
- b) Sponsor spaces and dimensions, as outlined the ITU Uniform Rules. The athlete's family name and NF code positions (front and back) and dimensions of both.
- c) The position and dimensions of the ITU logo. The colour(s) used in the design, including the pantone. The proposed design may be submitted in .jpg .gif .bmp or .tif format.

4.2 Once approved, the Uniform approval is extended till the the NF must seek approval for a new design.

### 5. Approval:

5.1 ITU will inform each NF in writing about the approval or disapproval of their NFs uniform if the design is:

- a) Compliant with all the ITU Uniform Rules.
- b) Distinct from other NF designs.

5.2 If the request is not approved ITU will:

- a) Ask the NF for a new design if the submitted one did not comply with the ITU rules, or
- b) Ask the NFs that submitted similar requests to agree to modifying their proposed designs in order to have different uniforms.

- c) If the NFs do not get an agreement ITU will decide on which NF can use the proposed design according with these priorities.
  - The NF that used the proposed uniform in the past will be given preference.
  - If both NFs are proposing new uniforms, a draw will be conducted to choose which NF will use the submitted design and which NF(s) will have to submit a new one.
- 5.3 ITU will produce an electronic catalogue of approved NF's competition uniforms. This catalogue will be updated monthly.
- 5.4 Requests for uniform approval received will be considered on a monthly basis. NFs requesting approval will choose designs that are different from those already approved.

## **6. Approval Panel:**

- 6.1 All decisions on uniform approval will be made by a panel composed of:
  - a) An ITU Technical Committee member.
  - b) A representative of the ITU Sport Department.
  - c) A member of the ITU World Championships Series Commission.
  - d) A representative of the ITU Media and Television Department.
  - e) A representative of the ITU Coaches Commission.
- 6.2 The decisions of the Approval Panel can be appealed to the ITU Executive Board. This appeal does not suspend the decision of the Approval Panel, but rather the decision will stay in place during the time the Executive Board takes to make a decision on the appeal.

**27. APPENDIX G: LINK TO PARATRIATHLON CLASSIFICATION MANUAL:**

- 1. Paratriathlon Classification Manual – available on [www.triathlon.org](http://www.triathlon.org)**

## 28. APPENDIX H: PRIZE MONEY BREAKDOWN:

### 1. Introduction:

- 1.1. The ITU Prize Money Percentages were created to provide a fair and equitable formula to distribute prize money to athletes.
- 1.2. If an ITU Event Organiser wants to modify these percentages, they must apply in writing to [events@triathlon.org](mailto:events@triathlon.org). If the modification is approved, it must be posted on the ITU event's webpage and on [www.triathlon.org](http://www.triathlon.org).
- 1.3. The amount and depth of prize money must be equal for women and men. There is no modification to this.
- 1.4. The prize money formula for the Dextro Energy Triathlon ITU World Triathlon Series has been modified to suit the Series and can be found on [www.triathlon.org](http://www.triathlon.org).

### 2. Percentages:

- 2.1. The table below shows the four basic prize money percentages.
- 2.2. For an easy tool to calculate the prize money percentage based on the event prize money, please visit [www.triathlon.org](http://www.triathlon.org).

	<b>Top 20</b> (150 001 USD and more overall prize money)	<b>Top 15</b> (50 001 -150 000 USD and more overall prize money)	<b>Top 10</b> (10 001 – 50 000 USD overall prize money)	<b>Top 5</b> (3 001 – 10 000 USD overall prize money)	<b>Top 3</b> (3 000 USD and less overall prize money)
<b>1.</b>	23,00%	25.00%	25.00%	30.00%	50.00%
<b>2.</b>	18,00%	20.00%	20.00%	25.00%	30.00%
<b>3.</b>	14,00%	15.00%	15.00%	20.00%	20.00%
<b>4.</b>	10,00%	10.00%	10.00%	15.00%	
<b>5.</b>	8,00%	7.00%	8.00%	10.00%	
<b>6.</b>	6,00%	6.00%	7.00%		
<b>7.</b>	4,00%	5.00%	6.00%		
<b>8.</b>	3,00%	3.00%	4.00%		
<b>9.</b>	2,30%	2.25%	3.00%		
<b>10.</b>	1,90%	1.75%	2.00%		
<b>11.</b>	1,60%	1.50%			
<b>12.</b>	1,40%	1.25%			
<b>13.</b>	1,20%	1.00%			
<b>14.</b>	1,10%	0.75%			
<b>15.</b>	1,00%	0.50%			
<b>16.</b>	0,90%				
<b>17.</b>	0,80%				
<b>18.</b>	0,70%				
<b>19.</b>	0,60%				
<b>20.</b>	0,50%				



## **29. APPENDIX I: ITU RELATED MULTISPORTS:**

- Triathlon
- Long Distance Triathlon
- Aquathlon
- Duathlon
- Winter Triathlon
- Cross Triathlon
- Cross Duathlon
- Indoor Triathlon

### 30. APPENDIX J: ITU EVENTS AND ITU EVENT CATEGORIES:

#### ITU Events

- World Championships
- World Triathlon Series
- World Triathlon Series Grand Final
- World Series
- World Cup
- Continental Championships
- Continental Cup
- Continental Cup Premium
- Continental Cup Final
- Continental Tour Event

#### ITU Event Categories

- Elite
- U23
- Junior
- Youth
- Paratriathlon
- Age-Group
- Team Relay

ITU events	Categories
World Championships. Triathlon Olympic Distance	U23, Age Group
World Championships. Triathlon Sprint Distance	Junior, Age Group, Paratriathlon
World Championships. Triathlon Team relay	Team relay.
World Championships. Triathlon Long Distance	Elite, Age Group, Paratriathlon
World Championships. Duathlon Standard Distance	Elite, U23, Age group
World Championships. Duathlon Sprint Distance	Junior, Age Group, Paratriathlon
World Championships. Duathlon Team relay	Team relay. Junior Team relay.
World Championships. Duathlon Long Distance	Elite, Age Group, Paratriathlon
World Championships. Winter triathlon.	Junior, U23, Elite, Age group. Team Relay. Paratriathlon (except TRI 1)
World Championships. Aquathlon.	Junior, U23, Elite, Age group, Paratriathlon
World Championships. Cross Triathlon.	Junior, U23, Elite, Age group, Paratriathlon (except TRI 1)
World Series. Triathlon. (Both Olympic and Sprint)	Elite
World Series Grand Final. Triathlon.	Elite
World Cup. Triathlon. (Both Olympic and Sprint)	Elite
World Cup. Winter Triathlon	Elite
World Series. Duathlon (Both standard and Long)	Elite
World Series. Long Distance Triathlon	Elite
Continental Championships. Triathlon Olympic distance	Elite, U23, Age Group
Continental Championships. Triathlon Sprint distance	Elite(*), Junior, Age Group(*), Paratriathlon
Continental Championships. Triathlon Long distance. (*)	Elite, Age Group, Paratriathlon.
Continental Championships. Triathlon team relay(*)	Team Relay, Junior Team relay. Youth Team relay
Continental Championships. Duathlon Standard distance.	Elite, U23, Age Group
Continental Championships. Duathlon Sprint distance(*)	Elite(*), Junior, Age Group(*), Paratriathlon
Continental Championships. Duathlon Team relay	Team relay, Junior Team relay
Continental Championships. Duathlon Long distance. (*)	Elite, Age Group, Paratriathlon.
Continental Championships. Winter triathlon (*)	Junior, U23, Elite, Age group. Team Relay. Paratriathlon (some categories –
Continental Championships. Aquathlon.(*)	Junior, U23, Elite, Age group, Paratriathlon
Continental Championships. Cross Triathlon.(*)	Junior, U23, Elite, Age group, Paratriathlon
Continental Cup (All distances and all multisports)	Elite
Continental Tour events	Elite
Junior Continental Cup. Triathlon (*)	Elite

### 31. APPENDIX K: PENALTIES AND VIOLATIONS:

Rules	Penalties
1. Compete within 48 hours in more than one event of the same individual related multisport;	- DSQ from all the events included in this period.
2. Starting before the starter's signal;	- Stop and Go - 15 seconds in T1
3. Failing to follow the prescribed course;	- Stop and Go and re-enter the race by the same point. If fails to that DSQ
4. Using abusive language or behaviour toward any official;	- DSQ and report to the EB for possible suspension
5. Using unsportsmanlike behavior;	- DSQ and report to the EB for possible suspension
6. Blocking, charging, obstructing, or interfering the forward progress of another athlete;	- Unintentionally: verbal warning - Intentionally: DSQ
7. Unfair contact. The fact that contact occurs between athletes does not constitute a violation. When several athletes are moving in a limited area, contact may occur. This incidental contact between athletes in equally favourable positions, is not a violation;	- Unintentionally: verbal warning - Intentionally: DSQ
8. Accepting assistance from anyone other than a Technical Official or race official;	- If it is possible to amend and return to the original situation Stop and Go - If not: DSQ
9. Refusing to follow the instructions of Technical Officials or race officials;	- DSQ
10. Departing the course for reasons of safety, but failing to re-enter at the point of departure;	- Unintentionally: verbal warning, and correct if possible
11. Failure to wear the unaltered race numbers if provided by the Local Organizing Committee, in the proper way ordered by the Technical Delegate and announced at the Athletes' Briefing;	- Unintentionally: verbal warning, and correct if possible (i.e. before the race) - Intentionally: DSQ
12. Leaving equipment or discarding personal articles on the course. Tyres, plastic bottles, and other discarded items must be placed safely off the course;	- Stop and Go, when amended - If not: DSQ
13. Wearing items deemed a hazard to self or others;	- Stop and Go, when amended - If not: DSQ
14. Using unauthorized equipment to provide an advantage or which will be dangerous to others;	- Stop and Go, when amended - If not: DSQ

15. Violating race-specific traffic regulations;	<ul style="list-style-type: none"> <li>- Unintentionally: verbal warning, and correct if possible</li> <li>- Intentionally: DSQ</li> </ul>
16. Contrived or intentional ties by elite, U23 and junior athletes in ITU sanctioned events;	<ul style="list-style-type: none"> <li>- DSQ</li> </ul>
17. Not attending the Athletes' Briefing, but informing The TD about the absence;	<ul style="list-style-type: none"> <li>- Athlete not attending the briefing, but who have informed the TD about their absence, will be reallocated to the last position on the pre-start line up;</li> <li>- For the World Championship Series or Triathlon World Cup events, if an athlete misses more than two briefings in a calendar year, they will be removed from the start list for the third missed briefing and each missed briefing thereafter;</li> </ul>
18. Not attending the Athletes' Briefing, without notifying the TD;	<ul style="list-style-type: none"> <li>- Athletes not attending the briefing, without informing the TD about their absence, will be removed from the start list.</li> </ul>
19. Wearing a different uniform than the one presented in the check-in;	<ul style="list-style-type: none"> <li>- If the new uniform complies with the rules. Warning</li> <li>- If not: DSQ</li> </ul>
20. Fraud by entering under an assumed name or age, falsifying an affidavit, or giving false information;	<ul style="list-style-type: none"> <li>- DSQ and inform ITU EB for a possible suspension</li> </ul>
21. Participating when not eligible;	<ul style="list-style-type: none"> <li>- DSQ and inform ITU EB for a possible suspension</li> </ul>
22. Repeated violations of ITU Rules;	<ul style="list-style-type: none"> <li>- DSQ and inform ITU EB for a possible suspension</li> </ul>
23. Drug abuse;	<ul style="list-style-type: none"> <li>- Penalties will apply according to the WADA rules</li> </ul>
24. For an unusual and violent act of unsportsmanlike behaviour;	<ul style="list-style-type: none"> <li>- Expulsion</li> </ul>
25. Compete with a bare torso;	<ul style="list-style-type: none"> <li>- Stop and Go when amended</li> <li>- If not: DSQ</li> </ul>
26. To change the start position once selected;	<ul style="list-style-type: none"> <li>- Warning and amend.</li> <li>- If not DSQ</li> </ul>
27. To block more than one start positions;	<ul style="list-style-type: none"> <li>- DSQ</li> </ul>
28. Make forward progress without the bike, during the bike segment;	<ul style="list-style-type: none"> <li>- Stop and Go when amended</li> <li>- If not: DSQ</li> </ul>
29. Nudity or indecent exposure;	<ul style="list-style-type: none"> <li>- DSQ</li> </ul>
30. Draft in a draft-illegal race on sprint distance events;	<ul style="list-style-type: none"> <li>- 1st offence: 1 minute in the next penalty box</li> <li>- 2nd offence: DSQ</li> </ul>
31. Draft in a draft-illegal race on standard distance events;	<ul style="list-style-type: none"> <li>- 1st offence: 2 minutes in the next penalty box</li> <li>- 2nd offence: DSQ</li> </ul>
32. Draft in a draft-illegal race on long distance events;	<ul style="list-style-type: none"> <li>- 1st and 2nd offences: 5 minutes in the next penalty box</li> <li>- 3rd offence: DSQ</li> </ul>
33. Not stopping in the next penalty box being obliged to do so;	<ul style="list-style-type: none"> <li>- DSQ</li> </ul>

34. Wearing the helmet unfastened or unsecurely fastened, during the bike segment;	<ul style="list-style-type: none"> <li>- Stop and Go when amended</li> <li>- If not: DSQ</li> </ul>
35. Take off the helmet on the bike course, even if stopped;	<ul style="list-style-type: none"> <li>- Stop and Go when amended</li> <li>- If not: DSQ</li> </ul>
36. Not wearing a helmet during the bike segment;	<ul style="list-style-type: none"> <li>- DSQ</li> </ul>
37. Compete with illegal or unauthorized equipment;	<ul style="list-style-type: none"> <li>- Stop and Go when amended</li> <li>- If not: DSQ</li> </ul>
38. Crawl during the running segment;	<ul style="list-style-type: none"> <li>- DSQ</li> </ul>
39. Run without shoes during any part of the running segment;	<ul style="list-style-type: none"> <li>- DSQ</li> </ul>
40. Run or ski wearing a helmet;	<ul style="list-style-type: none"> <li>- DSQ</li> </ul>
41. Rack the bike outside the athletes' own space;	<ul style="list-style-type: none"> <li>- Before the race warning and amend</li> <li>- During the race: <ul style="list-style-type: none"> <li>- Age-Group: Stop and Go when amended</li> <li>- Elite: 30 seconds in the penalty box (Long distance)</li> <li>- Elite: 15 seconds in the penalty box (Standard distance)</li> <li>- Elite: 10 seconds in the penalty box (Sprint distance)</li> </ul> </li> </ul>
42. Mount the bike before the mount line;	<ul style="list-style-type: none"> <li>- Age-Group: Stop and Go when amended</li> <li>- Elite: 30 seconds in the penalty box (Long distance)</li> <li>- Elite: 15 seconds in the penalty box (Standard distance)</li> <li>- Elite: 10 seconds in the penalty box (Sprint distance)</li> </ul>
43. Dismount the bike after the dismount line;	<ul style="list-style-type: none"> <li>- Age-Group: Stop and Go when amended</li> <li>- Elite: 30 seconds in the penalty box (Long distance)</li> <li>- Elite: 15 seconds in the penalty box (Standard distance)</li> <li>- Elite: 10 seconds in the penalty box (Sprint distance)</li> </ul>
44. Discharge or store the athlete equipment outside the designated area;	<ul style="list-style-type: none"> <li>- Stop and Go when amended</li> <li>- Elite: 30 seconds in the penalty box (Long distance)</li> <li>- Elite: 15 seconds in the penalty box (Standard distance)</li> <li>- Elite: 10 seconds in the penalty box (Sprint distance)</li> </ul>
45. To use posts, trees or other fixed elements to assist maneuvering curves;	<ul style="list-style-type: none"> <li>- Elite: 30 seconds in the penalty box (Long distance)</li> <li>- Elite: 15 seconds in the penalty box (Standard distance)</li> <li>- Elite: 10 seconds in the penalty box (Sprint distance)</li> </ul>
46. Team relay exchange completed outside of the exchange zone;	<ul style="list-style-type: none"> <li>- Team DSQ</li> </ul>
47. Warming up on the course while another race is in progress;	<ul style="list-style-type: none"> <li>- Warning and amend</li> <li>- If not amended: DSQ</li> </ul>

48. Wearing clothing covering any part of the arms below the shoulder and/or clothing covering any part of the legs below knee, in a non-wetsuit swim.	<ul style="list-style-type: none"> <li>- Warning and amend</li> <li>- If not amended: DSQ</li> </ul>
49. Use of illegal equipment on the bike and/or run, including but not limited to headphones, glass containers, mobile phones, uniform not complying with ITU Uniform Rules;	<ul style="list-style-type: none"> <li>- Warning and amend</li> <li>- If not amended: DSQ</li> </ul>
50. Marking of position in Transition Area;	<ul style="list-style-type: none"> <li>- Warning and amend</li> <li>- If not amended, marking will be removed and athlete will not be notified</li> </ul>
51. Competing under suspension	<ul style="list-style-type: none"> <li>- DSQ and report to EB for extending suspension or expulsion.</li> </ul>
52. Paratriathletes , who use catheters or other urinary diversion devices, have spillage during training, competition or classification	<ul style="list-style-type: none"> <li>- Warning and amend</li> <li>- If not amended: DSQ</li> </ul>
53. Paratriathlete competing in a paratriathlon competition by using none proper equipment	<ul style="list-style-type: none"> <li>- Before the race warning and amend</li> <li>- If not amended: DSQ</li> </ul>
54. Paratriathlete racing in a competition, which doesn't provide classification, without a temporary,,review or confirmed class status	<ul style="list-style-type: none"> <li>- DSQ</li> </ul>
55. Paratriathlete compete wearing or using any prostheses or special adaptive equipment which are not officially approved	<ul style="list-style-type: none"> <li>- Before the race warning and amend</li> <li>- If not amended: DSQ</li> </ul>
56. Paratriathlete, not compereting during the paratriathlon classification process	<ul style="list-style-type: none"> <li>- Warning and amend</li> <li>- If not amended: DSQ</li> </ul>
57. Athlete who have been evaluated as unclassified during the paratriathlon classification process	<ul style="list-style-type: none"> <li>- Remove from the start list</li> </ul>
58. Athlete who have been non eligible for a paratriathlon competition	<ul style="list-style-type: none"> <li>- Remove from the start list</li> </ul>
59. Paratriathlete fails to attend scheduled classification session	<ul style="list-style-type: none"> <li>- Reasonable explanation: Give second chance</li> <li>- If not: DSQ</li> </ul>
60. Paratriathlete who is intentionally misrepresenting his/her skills and/or abilities.	<ul style="list-style-type: none"> <li>- DSQ</li> <li>- not allow the paratriathlete to undergo any further evaluation for a minimum of two (2) years from the date upon which the paratriathlete intentionally misrepresented skills and/or abilities;</li> <li>- remove any Sport Class or Sport Class Status allocated to the paratriathlete from the Classification Master List;</li> <li>- designate the paratriathlete as IM (intentional misrepresentation) in the <i>Classification Master List</i>;</li> <li>- Second offense:: lifetime ban from any ITU events.</li> </ul>

61. Guides and handlers, who have not registered at the athletes' briefing	- Do not have access to the FOP
62. Personal handler not carrying the special credentials which were given by the LOC/ITU	- Warning and amend - If not amended: DSQ the paratriathlete that they are handling
63. Paratriathlete receiving help from more handlers that he/she has register	- DSQ
64. Any action taken by the handler which propels the competitor forward	- DSQ the paratriathlete that he/she is handling
65. Handler repairing a paratrithletes bike in an area other than the athletes' transition spot or the wheel station during the race	- DSQ
66. Paratriathletes' equipments in the pre-transition area which haven't been registered	- Before the race warning and amend - If not amended: DSQ
67. Personal handlers' presense in the pre-transition area from TRI2, TRI3, TRI4, TRI5, TRI6	- Before the race warning and amend - If not amended: DSQ the athlete that they are handling
68. TRI6 athlete competing with a guide who is not complying the requiremnets	- DSQ
69. TRI6 athletes not be tethered during the swim or the run	- Before the race warning and amend - If not amended: DSQ
70. TRI6 athletes paced, leaded or being more than 0.5m away from their guide, during the swim	- 15 seconds in T1 - Second offence: DSQ
71. TRI6 athletes paced, leaded or being more than 0.5m away from their guide, during the run	- First offence:15 seconds in the next penalty box - Second offence: DSQ
72. Tri 6 athletes pulled or pushed by the guide	- DSQ
73. TRI6 athletes not waring the black out glasses	- DSQ
74. TRI6 competitor crosses the finish line and the guide is beside or behind the competitor but further apart than the required 0.5 metres maximum separation distance	- DSQ
75. Paratriathlete enters the FOP with a use of a guide dog	- Before the race warning and amend - If not amended: DSQ