

SLD336VF

Description

The SLD336VF is a 750 mW high power laser diode designed to have a uniform emission area that is suitable for the applications for solid-state laser excitation, measurement and printing, etc. It adopts a $\phi 5.6$ package that is easy to handle.

(Applications: solid-state laser excitation, measurement and printing)

Features

- ◆ High-power
Recommended optical power output $P_o = 750$ mW
- ◆ High-optical power density: 750 mW/75 μm (Emitting line width)

Structure

- ◆ AlGaAs quantum well structure laser diode

Absolute Maximum Ratings

(Tc = 25 °C)

◆Optical power output	Pomax	825	mW
◆Reverse voltage	V _R LD	2	V
◆Operating temperature (Tc)	Topr	+ 10 to + 35	°C
◆Storage temperature	Tstg	- 40 to + 85	°C

Operating Lifetime

◆MTTF 10,000 h (effective value) at Po = 750 mW, Tc = 25 °C

Warranty

This warranty period shall be 90 days after receipt of the product or 1,000 hours operation time, whichever is shorter. Sony Quality Assurance Department shall analyze any product that fails during the warranty period, and if the analysis results show that the product failed due to material or manufacturing defects on the part of Sony, the product shall be replaced free of charge.

Laser diodes naturally have differing lifetimes which follow a Weibull distribution.

Connection Diagram

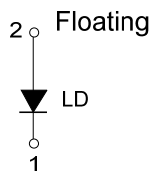

Pin Configuration

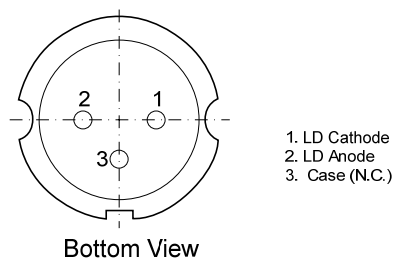

Electrical Characteristics

(T_c = Case temperature, T_c = 25 °C)

Item	Symbol	Conditions	Min.	Typ.	Max.	Unit		
Threshold current	I _{th}			0.2	0.3	A		
Operating current	I _{op}	P _o = 750 mW		0.8	1.0	A		
Operating voltage	V _{op}	P _o = 750 mW		2.0	3.0	V		
Wavelength	λ _p	P _o = 750 mW	790		840	nm		
Radiation angle	Perpendicular	θ _⊥	P _o = 750 mW	18	23	30	degree	
	Parallel	θ _{//}	P _o = 750 mW	5	9	12	degree	
Positional accuracy	Position	ΔX				± 80	μm	
		ΔY		- 170	- 90	- 10	μm	
	Angle	Δθ _⊥	P _o = 750 mW				± 3.0	degree
		Δθ _{//}	P _o = 750 mW				± 5.0	degree
Differential efficiency	η _D	P _o = 750 mW		1.2		W/A		

Notes on Handling

Care should be taken for the following points when using this product.

1. This product corresponds to a Class 4 product under IEC60825-1 and JIS standard C6802 "Laser Product Emission Safety Standards".

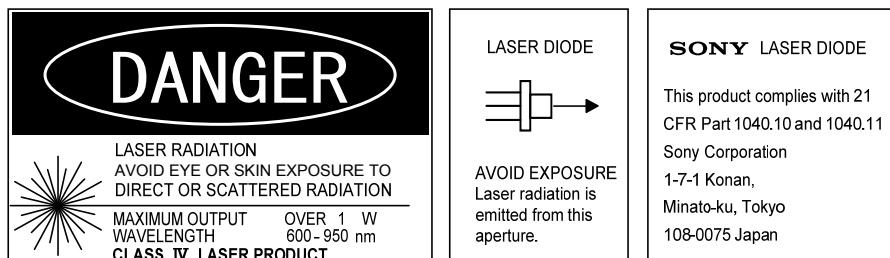

2. Eye protection against laser beams
Take care not to allow laser beams to enter your eyes under any circumstances
For observing laser beams, ALWAYS use safety goggles that block laser beams. Usage of IR scopes, IR cameras and fluorescent plates is also recommended for monitoring laser beams safely.
3. Gallium Arsenide
This product uses gallium arsenide (GaAs). This is not a problem for normal use, but GaAs vapors may be potentially hazardous to the human body. Therefore, never crush, heat to the maximum storage temperature or higher, or place the product in your mouth.
In addition, the following disposal methods are recommended when disposing of this product.
 - (1) Engaging the services of a contractor certified in the collection, transport and intermediate treatment of items containing arsenic.
 - (2) Managing the product through to final disposal as specially managed industrial waste which is handled separately from general industrial waste and household waste.
4. Prevention of surge current and electrostatic discharge
Laser diodes are most sensitive to electrostatic discharge among semiconductors. When a large current is passed through the laser diode for even an extremely short time, the strong light emitted from the laser diode promotes deterioration and then destruction of the laser diode. Therefore, note that surge current should not flow to the laser diode driving circuit from switches and others. Also, if the laser diode is handled carelessly, it may be destroyed instantly because electrostatic discharge is easily applied by a human body. Therefore, be extremely careful about overcurrent and electrostatic discharge. Also, use the power supply that was designed not to exceed the optical power output specified at the absolute maximum ratings.
5. Use for special applications
This product is not designed or manufactured for use in equipment used under circumstances where failure may pose a risk to life and limb, or result in significant material damage, etc.
Consult your Sony sales representative when investigating use for medical, vehicle, nuclear power control or other special applications.
6. Environment-related Substances to be Controlled
No substances classified at Level 1 (immediate ban) of Sony Technical Standard, SS-00259, "Management regulations for the Environment-related Substances to be Controlled". The excerpt from SS-00259 is introduced on following URL
<http://www.sony.net/SonyInfo/procurementinfo/ss00259/>

Package Outline

(Unit : mm)

M-S042

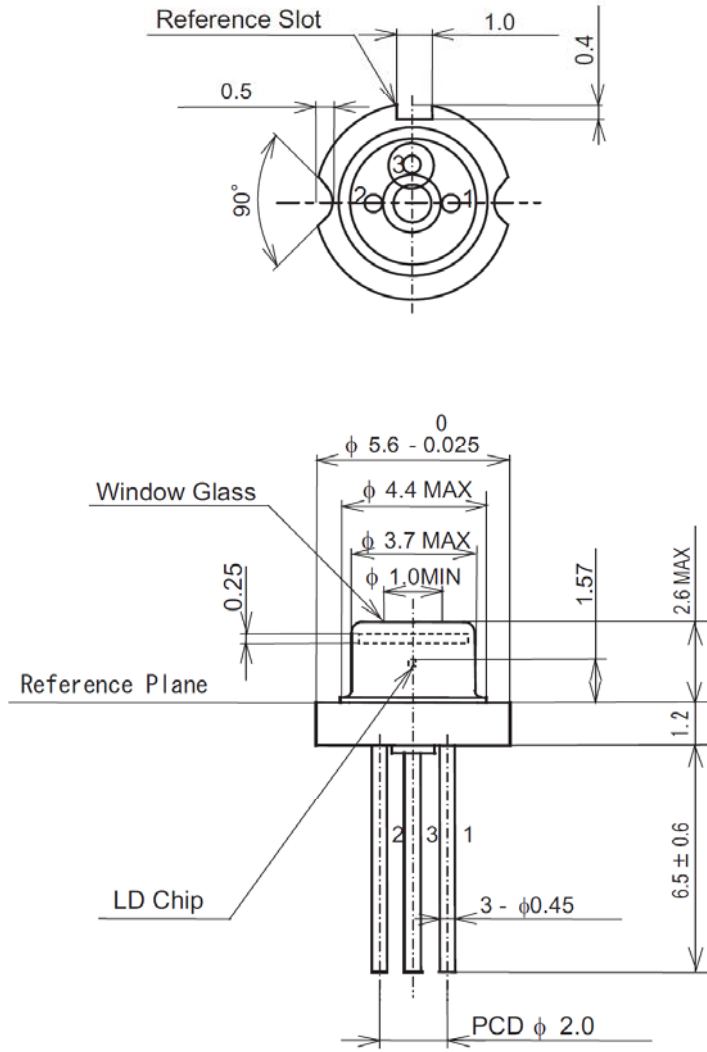

Note

Sony reserves the right to change products and specifications without prior notice.

This information does not convey any license by any implication or otherwise under any patents or other right.

Application circuits shown, if any, are typical examples illustrating the operation of the devices. Sony cannot assume responsibility for any problems arising out of the use of these circuits.