

TEMPERATURE SWITCHING ANALYZER

Mrs. S. J. KULKARNI, PROF. S. N. PAWAR, Ms. M.S.TADPATRIKAR

ABSTRACT: Electrical characterization, such as measurement of the I-V characteristics of electronic devices with respect to change in temperature is necessary for application of such devices. In our project, we report the development of a simple low-cost system for the measurement of I-V characteristics associated with changing surrounding temperature. The temperature switching analyzer developed basically consists of a PIC micro controller based Master/Slave configuration for monitor and control for electronic devices along with high-speed data acquisition system. The design aspects of the system, its interface, to the high-speed data acquisition system and the personal computer, and the details of the application software developed are described.

KEY WORDS: I-V characteristics, PIC micro controller, Temperature switching analyzer

1. INTRODUCTION

The aim is to design and implement a simple low cost Electrical/Electronic temp switching analyzer. The hardware components of the system consists of micro controller based Master/Slave configuration for temp monitor and control and a high-speed data acquisition system for current and voltage ratings. The Master controller is designed for temperature monitoring and is visualized by LCD. LM35 is used as a temp sensing device. As the temperature monitored and when the upper and lower cut off temp is set the heating chamber power is made on until the max temp is reached. As the max temp is obtained the AC power is made off. Relays are used to control these actions. The Master PIC microcontroller controls three relays; one of them is used for controlling the heating chamber operation. Second and Third relay are used to operate the temp sensing electronic devices. The analog values given out by the temp sensing devices are converted to digital signals and passed to computer through serial communication protocol. The Slave PIC microcontroller does the operation of digital conversion of analog inputs coming in from two channels. A switching mechanism is utilized here so that the DAC comes into picture and the Slave generates sine, square, triangular waves. The application software is continuously waiting for the digital data coming from the hardware and is designed to develop the graphical presentations such as 1) Voltage v/s Time 2) Current v/s Time 3) Voltage v/s Current. The application s/w is developed in VB6.0. It is designed to generate the respective characteristic graph as well as it has got facility to store the data in database and resume when ever required.

1. Mrs. S. J. KULKARNI, 2. PROF. S. N. PAWAR
3. Ms. M.S.TADPATRIKAR

1. Sr. Lecturer, E & TC Dept., P.D.V.V.P. Polytechnic, Loni.
2. Asst. Prof., E & TC Dept. , JNEC, Aurangabad.
3. Sr. Lecturer, E & TC Dept., Modern College of Engg, Pune.

1. kulkarni.suchita123@gmail.com
2. mugdha_st@yahoo.com

2. FEATURES OF THE PROJECT

The protocol developed consists of various electronic monitoring and controlling protocols like-

- It can work as computer operated digital thermometer for indication of room temperature as well as storage of the variations with respect to time.
- A PIC16f 877A microcontroller based Master temperature controlling device which controls the heating chamber switching.
- 16x2 LCD display to display the temperature.
- A Sine, Triangular and square wave generation using DAC 0800.
- The application software can also be used as signal storing device as the signal coming in digital binary form is stored and can be re produced as per requirement at times.

3. FUNCTIONAL BLOCK DIAGRAM

Fig.1 shows the block diagram of Electrical/ Electronic switching analyzer. The various blocks are explained as follows. The design of each sub-block is also explained.

A. Signal conditioning block

Signal conditioning is widely used term in the world of data acquisition. The most common transducers produce an output in the form of voltage, current, charge, capacitance and resistance. However, we need to convert these signals to voltage in order to send input to A-to-D converter. This conversion is commonly called as signal conditioning. The Temperature sensors components used in the protocol are LM-35

B. Microcontroller-Based Wave Form Generation Source

The microcontroller-based Wave Form Generation source is designed to function as a programmable voltage Wave Form Generation source depending on the parameter given through hyper terminal. This unit has features to generate different types of waveforms such as triangular, ramp, step. etc. with single or multiple cycles. The instrument receives the commands from the computer through the serial port and outputs the required different types of waveforms such as triangular, ramp, step. etc

C. Microcontroller-Based Temperature controller and Monitoring System

It consists of a transformer, rectifier, filter, a digital-to-analog converter (DAC). A in build ADC module, A pair of PIC 16f877 microcontroller boards in master slave configuration for intelligent control, Relay board with relay drivers an RS-232 driver to interface to the computer, and the associated power supplies.

D. PIC micro controller

Microcontroller is the heart of this system. It handles all the operations of the system. In this dissertation PIC16F877 is used. It is a 8-bit PIC microcontroller (PIC16F877) having 16-kB EPROM, 256-B RAM, three 16-bit timer/counters, and four 8-bit bi-directional ports.

4. HARDWARE DESIGN

The Master PIC microcontroller controls three relays; one of them is used for controlling the heating chamber operation. Second and Third relay are used to operate the temp sensing electronic devices. The analog values given out by the temp sensing devices are converted to digital signals and passed to computer through serial communication protocol. The Slave PIC microcontroller does the operation of digital conversion of analog inputs coming in from two channels. A switching mechanism is utilized here so that the DAC comes into picture and the Slave generates sine, square, triangular waves. Thus the project can be viewed as consisting of four modules, namely,

- Master Temperature Monitoring Unit
- Master Temperature Controlling Unit
- Slave ADC and Serial communicating protocol
- Slave Waveform Generator Unit

Following figure shows block diagram for Electrical /Electronic Temperature Switching Analyzer.

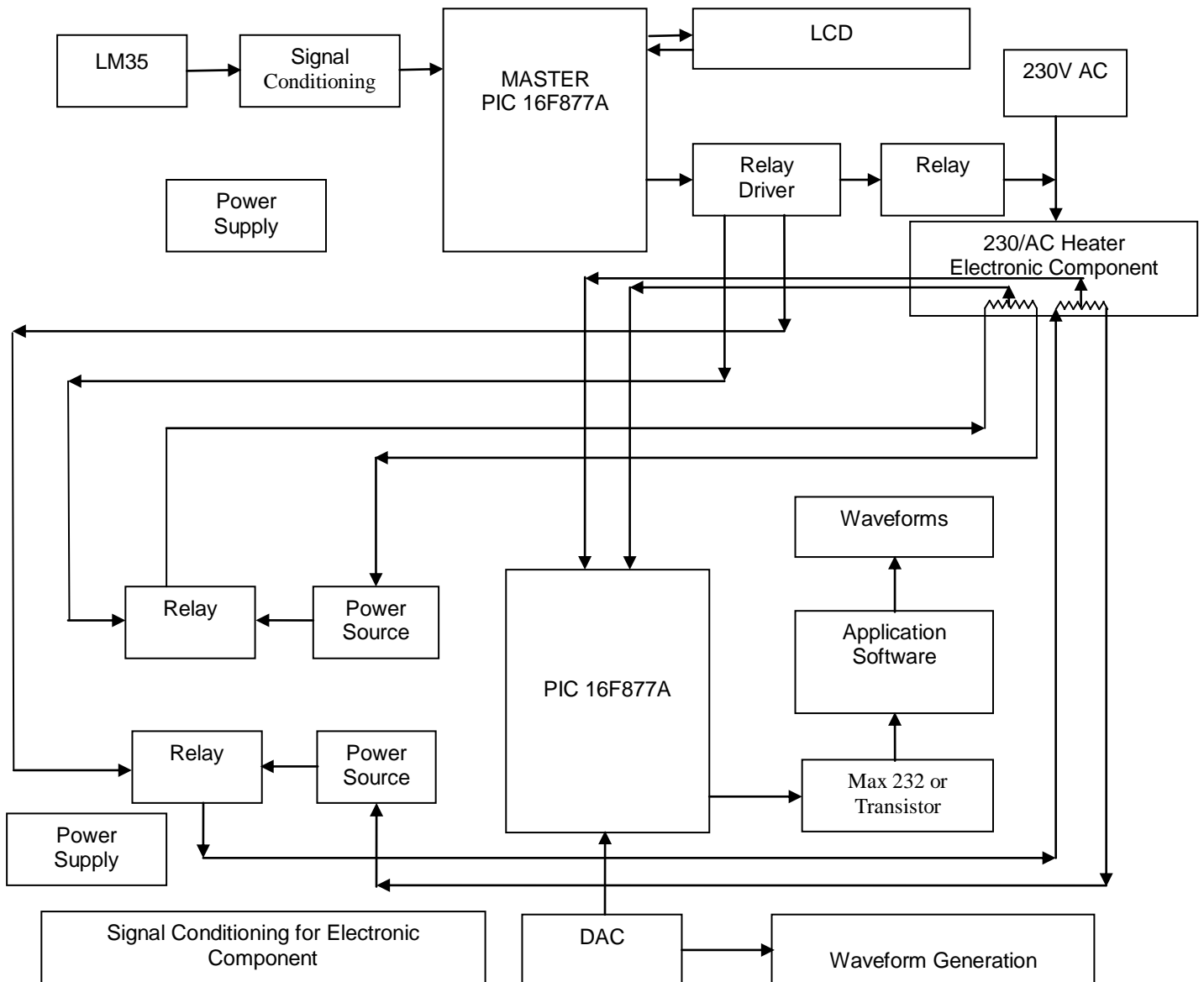

Figure 1: Block Diagram of Electrical /Electronic Temperature Switching Analyzer

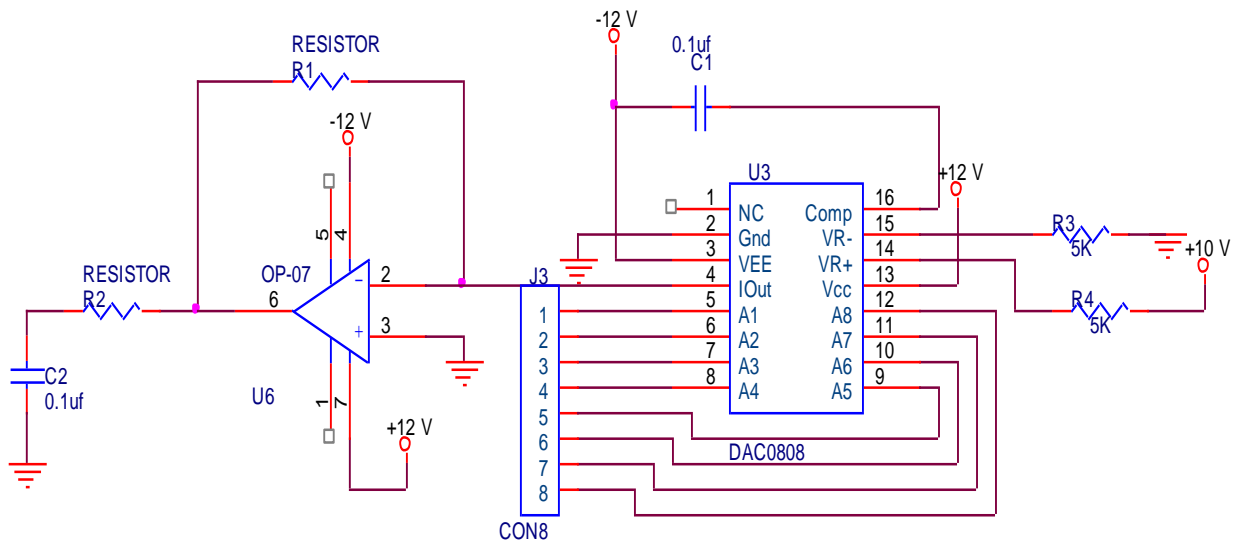

Figure 4: Wave Form Generation DAC0808 Circuit Diagram

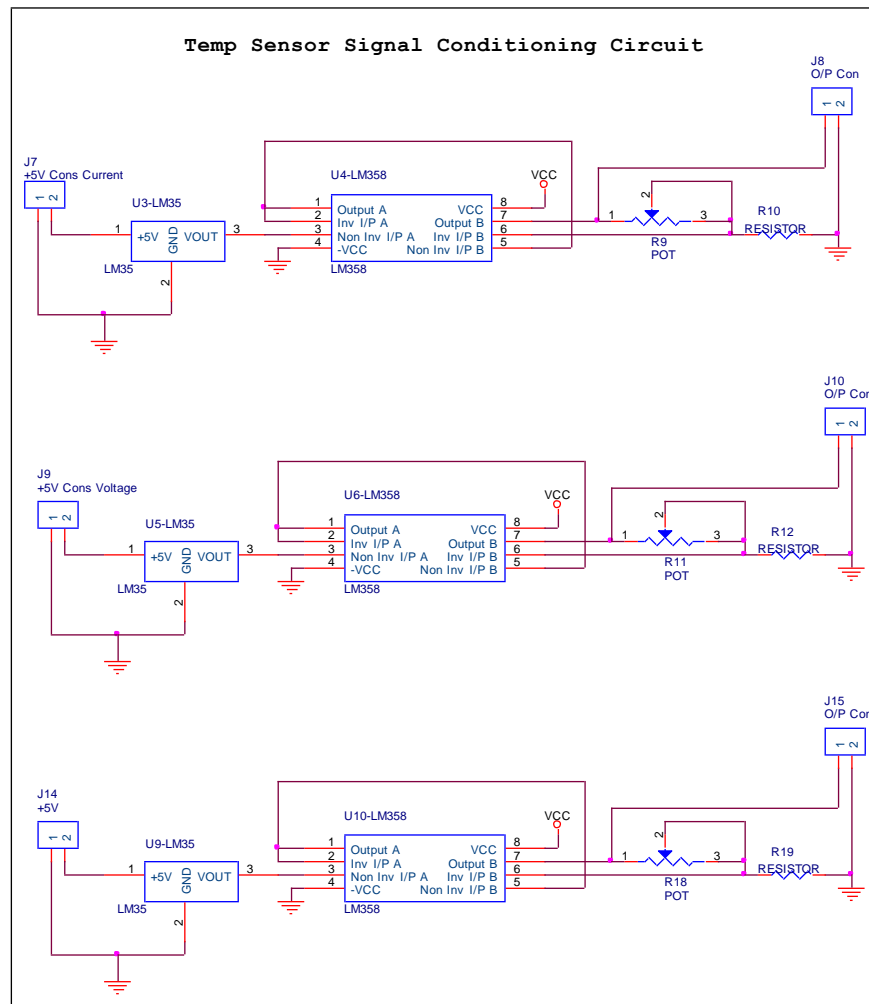

Figure 5: Temperature sensor signal conditioning circuit

5. SOFTWARE DEVELOPMENT

The application software for the total system consists of master slave modules, the code for the PIC-microcontroller master temperature monitor and control and the slave for analog to digital conversion of the received voltage and serial transmission to generate the necessary plots on computer. The slave is also designed to generate various user required waveforms. The software at the PC end providing the user interface, and also the protocol for communication between the PC and the Master and slave microcontroller unit.

ALGORITHM

1. Start.
2. Handshaking initialization (ctrl + A).
3. Input range for temperature controlling via serially.
4. Increase temperature of temperature sensor.
5. Continuously compare temperature ranges.
6. if($adc_val > l_value$ && $adc_val < U_value$).Then SET temperature, Voltage, current relays ON.
7. Else SET them OFF.
8. Transmit both voltages and current value via serially
9. Plot the respective graphs on VB.
10. Generate the readings table using VB.

6. RESULT & OBSERVATIONS

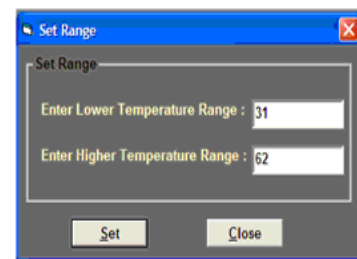
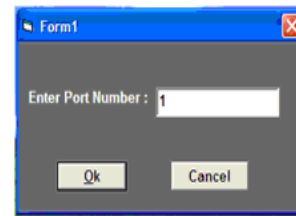

Waveforms generated

