

Sms-Based Home Management System

Paing Soe Oo, Zaw Myo Tun, Hla Myo Tun

ABSTRACT: Mobile phones are widely used nowadays, for different application such as wireless control and monitoring due to its availability and ease of use. The implemented system is based on "global system mobile (GSM)" network by using "short message service (SMS)". The design mainly contains a GSM modem and Arduino Uno. In this work, the system will be described how to manage and control home appliances using mobile phone, people can use this system to do things in their home from a far place before they reach home. For instance, user may control/manage his/her home lighting, door or water pump which needed in daily life in different area (House, Office, or factory, etc.) when they are away from home. The user can check the condition in the home that light is on or off, door is locked or unlocked, water pump is on or off and so on. If the time taken for this appliances to perform a task is known that can also be set, so that if the time elapsed the appliance will automatically switch off itself. The control is done by sending a specific SMS messages from smart phone to a SIM900 and Arduino Uno which is connected to the appliance, once the message is received the SIM 900 will send the command to a microcontroller in Arduino for controlling the appliance appropriately. Also feedback status of three devices can be requested in designed system.

Keywords: Remote control; home appliances; mobile phone; SMS; GSM; SIM 900, Arduino.

1. INTRODUCTION

Home management System is a project used to control any devices in home or in office or in other places can switch on or off. The goal of a smart home system on enabling those who live in them to control a large number of electronic devices easily and remotely. A simple smart home system might, for instance, turn on the lights, turn off the alarm when the garage door opener activates and turn on motor when water level is low. Smart homes typically have many more complicated systems, but they all operate via the same principles. Smart homes work via fairly simple systems: Arduino Uno, SIM 900 and SMS. Normal home devices such as lights, entertainment systems, heaters, air conditioners, computers, security systems and radios are equipped with receivers. This SIM 900 receive a certain signal initiated by the code SMS, which can be housed in a control device such a light switch or, most commonly, a remote control. In order to design the remote control smart home system in this work, this system can control by using Short Message Service (SMS). Nowadays, Short Message Service (SMS) is widely used as a form of data communication. It is about 2.4 billion active users which equals to 74% of mobile phone subscribers sending and receiving text messages on their phones. SMS is a communication application in Global System for Mobile communication (GSM) system. It allows interchange of short text messages between mobile telephone devices using standardized communication protocols. The system in this paper is design to receive the SMS from any mobile device to the GSM modem that connected to Arduino. In order to prevent any occurrence of SMS likelihood control words, the sending SMS that contain control words should come between the specified codes that protocol between user of far mobile phone and the GSM modem that connected to the microcontroller. After the GSM modem which connected to the microcontroller receives the sent message, it sends this message to the microcontroller in Arduino.

2. System Block Diagram

The art of designing SMS based home automation system is discussed in this article. SMS based control of appliances is a very popular application and the one with very much utility for different domains. Sometimes it becomes difficult to imagine and believe that mobile phone can act as a remote for the commonly used home

appliances and always connect to home through mobile phone no matter in which part of the world. SMS service can be used to control different appliances of the home and for that it is quite obvious that there must be an intelligent system installed at home which will receive the sms, read its content and finally will be able to perform the desired action for switching on/off the appliances. This type of intelligent system can be easily designed using microcontroller, gsm modem and some electro-mechanical relays. Fig. below shows a simple block diagram of the home automation system design using arduinouno development platform.

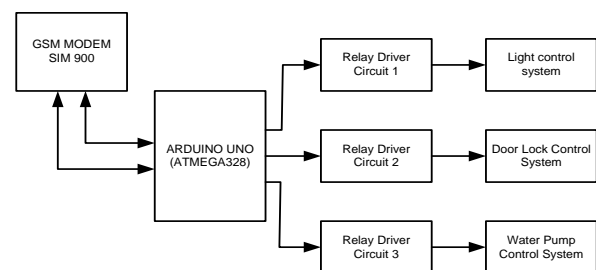

Figure 1. System Block Diagram

3. SYSTEM DESCRIPTION

The system has two parts, namely; hardware and software. The hardware architecture consists of a stand-alone embedded system that is based on Microcontroller (Arduino Uno), SIM 900 GSM Modem and a driver circuit. The GSM modem provides the communication media between the homeowner and the system by means of SMS messages. The SMS message consists of commands to be executed. The format of the message is predefined. The SMS message is sent to the GSM modem via the GSM public networks as a text message with a definite predefined format. Once the GSM modem receives the message, the commands sent will be extracted and executed by the GSM handset. The system will interpret the commands and turn the appliances ON/OFF accordingly via the switching module.

A. USER GSM MOBILE HANDSET

Cellular phone containing SIM (Subscriber's Identifying Module) card has a specific number through which communication takes place with GSM via radio waves. The

mode of communication is wireless and mechanism works on the GSM (Global System for Mobile communication) technology. Here, the user transmits instructions to the system to control the appliance in the form of SMS.

B. SIM 900 GSM Modem

This SIM 900 GSM Modem is used to receive the SMS sent by the user and then to transmit an acknowledgement or status to the user's mobile. The MODEM has to be equipped with an AT Modem and a valid SIM card. This MODEM is attached with the microcontroller (Arduino Uno) used to control the appliance.

C. Arduino Uno

Arduino Uno is the board we used in this project. The Uno is the most used and documented board of the whole Arduino family. The Uno is a microcontroller board based on the ATmega328P. It has 14 digital input/output pins, 6 analog inputs, a 16 MHz quartz crystal, a USB connection, a power jack, an ICSP header and a reset button. It contains everything needed to support the microcontroller; simply connect it to a computer with a USB cable or power it with a AC-to-DC adapter or battery to get started. Arduino Uno can be used without worrying too much about doing something wrong.

4. System Operation

GSM module (SIM900) is interfaced with arduino using serial pins (0 and 1). AT commands are sent to gsm modem for configuring it in sms mode and also to route the new incoming message to the serial reception pin of the arduino. The incoming message is decoded by the arduino and is compared with the predefined codes. If the match is found then the corresponding action for that code will be performed by the arduino. The following codes are used-

a1b1c1-----All devices on
 a1b1c0-----device 3 off
 a1b0c1-----device 2 off
 a1b0c0-----device 2 and 3 off
 a0b1c1-----device 1 off
 a0b1c0-----devices 1 and 3 off
 a0b0c1-----devices 1 and 2 off
 a0b0c0-----all devices off

If the received message contents are a1b1c1 then relay 1, 2, and 3 will be triggered through BC547 transistor and all devices are switched on, here transistor BC547 acts as a relay driver and it drives the relay. Similarly for other codes the corresponding programmed functions are performed.

Circuit Diagram

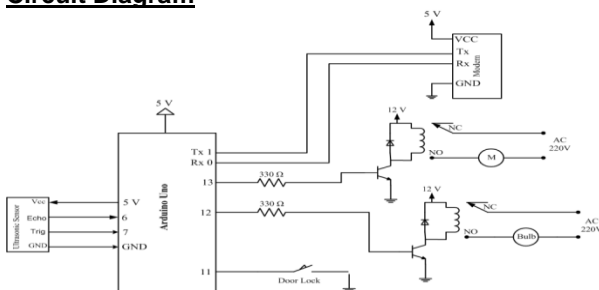

Figure 2. Circuit Diagram

AT COMMANDS to initialize GSM modem

AT+CNMI, New Message Indications to TE

This command selects the procedure, how receiving of new messages from the network is indicated to the DTE when DTE is active.

```
AT+CNMI=[<mode>[,<mt>[,<bm>[,<ds>[,<bfr>]]]]]
```

Here I have used the command-

```
AT+CNMI=2,2,0,0,0
```

<mode> value here is 2 which indicates buffer unsolicited result codes in the modem when modem-DTE link is reserved (e.g. in on-line data mode) and flush them to the DTE after reservation. Otherwise forward them directly to the DTE. The rules for storing received sms depends on its coding scheme, preferred memory storage (using command at+cpms) settings and the value of <mt> field that is specified in the at+cnmi command. Here I have used <mt> field value as 2 and this indicates that SMS-DELIVERs (except class 2 messages and messages in the message waiting indication group (store message)) are routed directly to the DTE using unsolicited result code +CMT:

<bm> field is set to 0 and this indicates that no CBM (Cell Broadcast Message) indications are routed to the DTE.

<ds> field is also set to 0 and this indicates that no SMS-STATUS-REPORTs are routed to the DTE.

<bfr> field is set to 0 and this means modem buffer of unsolicited result codes defined within this command is flushed to the DTE when <mode> 1 - 3 is entered (OK response shall be given before flushing the codes)

AT+CMGF, SMS Format

AT+CMGF=<mode>

mode = 0: PDU mode

mode = 1: Text mode

Here I have used the command AT+CMGF=1 and this configures the modem in the sms mode.

5. PROCESS FLOW

The first step in using this system is to send the command in form of SMS to the GSM Modem connected to the microcontroller, when the message is received it will now be stored in MODEM memory. The content of the message is examined to know what operation the user wants to perform; the whole process is illustrated in figure 3.

6. Simulation Results

In this part there is a series of decision statements for selecting the appliance, type of operation, etc. The message body must six character, which means a user wants to perform which device is either ON or OFF operation. The first character "a" represents the motor to drive, the middle character "b" represents the lighting control and the last character "c" is for door control. The number that represent the type of operation; one is ON

while zero is OFF. Each time a message is sent, it has to be sent to microcontroller which will then act on the appliance. For instance, the diagram in figure 5 is a message that will “a1b1c1”, while that of figure 4 is for all devices are ON.

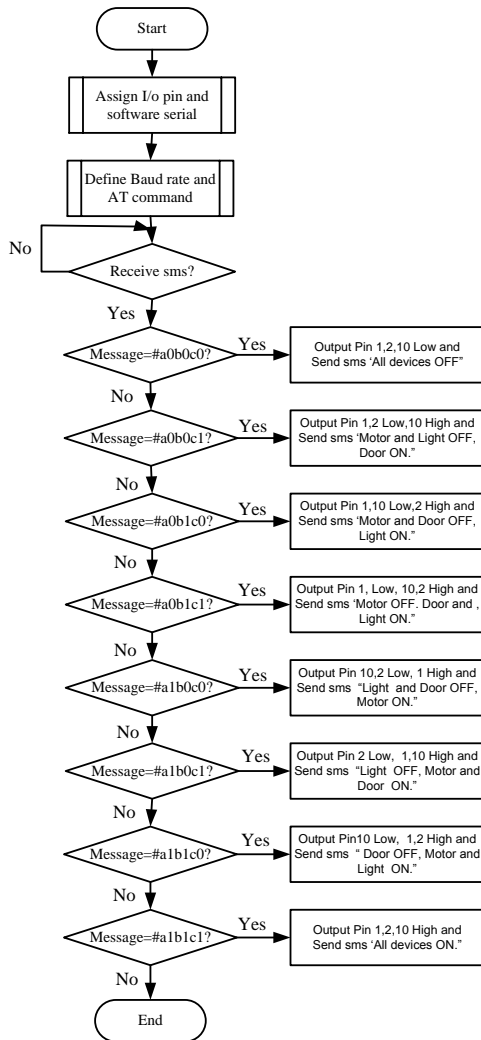

Figure 3. Flowchart of the System

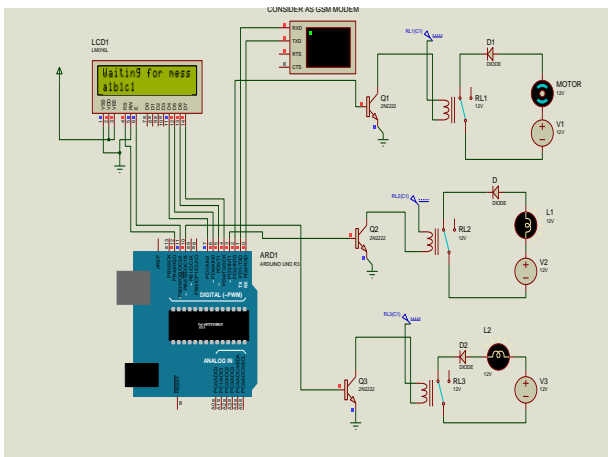

Fig: Simulation Result when all home appliances are turn on

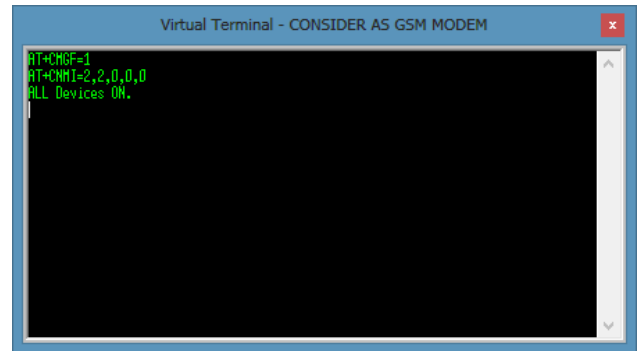

Figure: Display the text message of “All Devices ON”

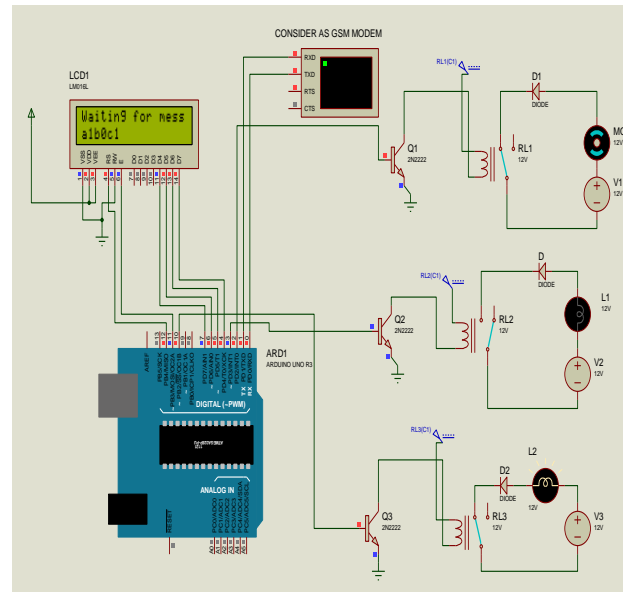

Fig: Simulation Result when two home appliances are turn on

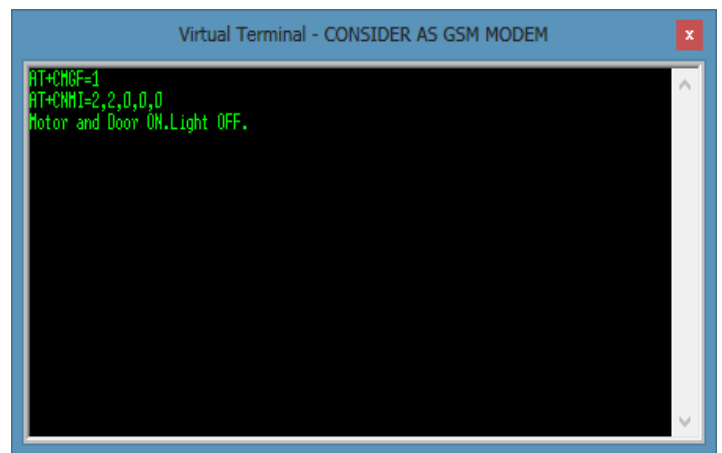

Figure: Display the text message “Motor and Door ON. Light Off”

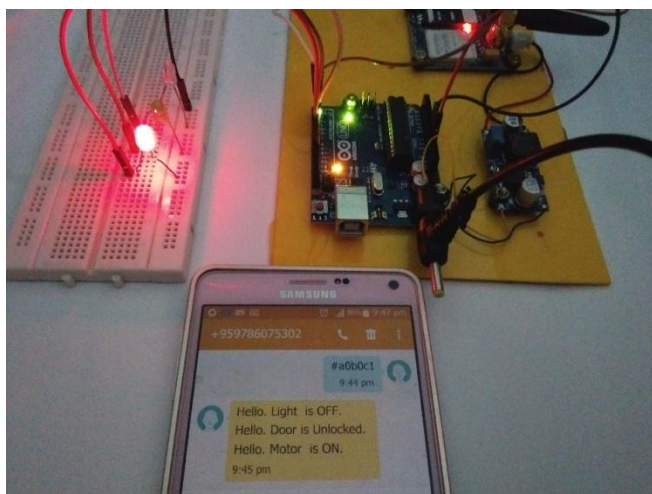

Figure: Experimental Result when motor is turn on



Figure: Experimental Result when three home appliances are turn off

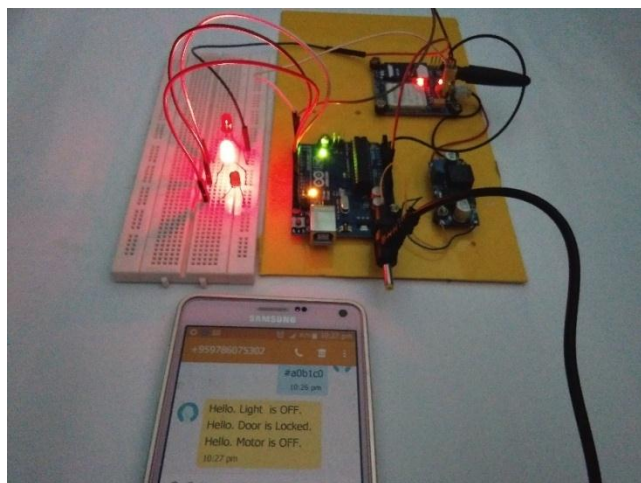

Figure: Experimental Result when door lock control system is turn on

7. CONCLUSION

This paper described how can develop a remote management and control system for home appliances, the system allows the user to start or stop appliances. With this system user can control up to three devices. This system is

- Controlling multiple appliances concurrently.
- Sending a confirmation message back to the user.
- Be able to know the status of the appliances.

REFERENCES

- [1] C. K. Das, M. Sanaullah, H. M. G. Sarower and M. M. Hassan, —Development of a Cell Phone Based Remote Control System: an Effective Switching System for Controlling Home and Office Appliances,|| International Journal of Electrical and Computer Sciences (IJECS), vol. 9, No. 10, pp. 37–43.
- [2] H. H. Goktas, N. Daldal, —A Cellular Phone Based Home/Office Controller and Alarm System,|| G. U. Journal of Science, vol. 19, pp.21– 26, 2006.
- [3] B. Ramamurthy, S. Bhargavi and R. Shashikumar, —Design and Implementation of GSM based Remote Monitoring and Control system for Industrial process Parameters,|| International Journal of Computer Science and Internet Security (IJCSIS) , vol. 8, No. 5, pp. 219–225. 2010.
- [4] Gowthami, Dr. Adilinemacriga "Smart Home Monitoring and Con trolling System Using Android Phone" International Journal of Emerg- ing Technology and Advanced Engineering Website: www.ijetae.com ISSN 2250-2459, ISO 9001:2008 Certified Journal, Volume 3, Issue 11, November 2013.