

Centralized Train Management System

Karan Savla¹, Vatsal Shah², Hemil Shah³, Darpan Damani⁴

¹karansavla999@gmail.com, ²vatsalshah20may@yahoo.com, ³shahemil@rediffmail.com, ⁴darpandamani93@gmail.com

Abstract - The project aims to establish an online centralized system for management of movement of local trains along the western railway. The western railway is a stretch of 60 kilometers between Churchgate station and Virar station. It handles about 1500 trains and more than a million passengers commute to different places on a daily basis. The manual system for getting details of train movement between station and controller did not always provide accurate information about the trains, thus causing inconvenience to the passengers. The management of trains is replaced by an online system and it also involves the use of video display units (VDUs) at each station to display the information about the movement of the train.

Key words: – Reed Switches, Microcontroller, I/R Module

Introduction

The earlier system was based on the assumption that the train would take 45 seconds to pass through each station and accordingly the chart showing arrival time of each train at each station was prepared.

But this was obviously not reliable and inaccurate. So there was a need to develop an ONLINE system for management of trains which would show minute to minute details of movement of trains. This is the main aspect covered under TRAIN MANAGEMENT SYSTEM.

1. OBJECTIVES OF SYSTEM

The main objectives of the TRAIN MANAGEMENT SYSTEM are:

- Implementation of VDUs at each station showing the scheduled arrival as per time table and expected arrival time of the next two trains.
- Implementation of indicator boards at each station which are directly operated from the system on ONLINE basis.
- Implementation of automatic train announcements from the control centre using available ONLINE information of the trains.
- Implementation of a system to avoid collision of two trains using concept of 'SAFE DISTANCE'.
- Implementation of a system which gives current status of all interlocking information like signals, points etc pertaining to various stations.
- Implementation of an interface between controller and train indicator boards for train arrival information.

2. SYSTEM ARCHITECTURE

- TMS is a centralized system which is operated using the computer from the control office: which collects the

- information about signaling system, tracks and points. The whole system is divided into three sections-station controller, train controller and signaling systems.

- **SIGNALLING SYSTEM:** They are classified as Signals, Tracks and Points. On basis of availability of tracks, signals give indications to the trains. The track is the route on which the train travels. The Point is the junction at which train changes its tracks.



REED SWITCH [1]

- **TRAIN CONTROLLER:** It has an 89C52 which controls the entire operation of railways. A signal is sent by the controller to the station controller, when the train crosses the reed switch. As a result, IR on the other train is active high. Only when the train in that section crosses the safe distance, the IR on the railway goes low and the train starts moving.

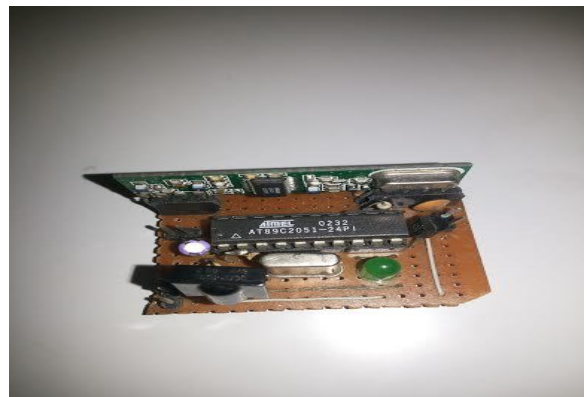

Fig 1. Train Controller [2]

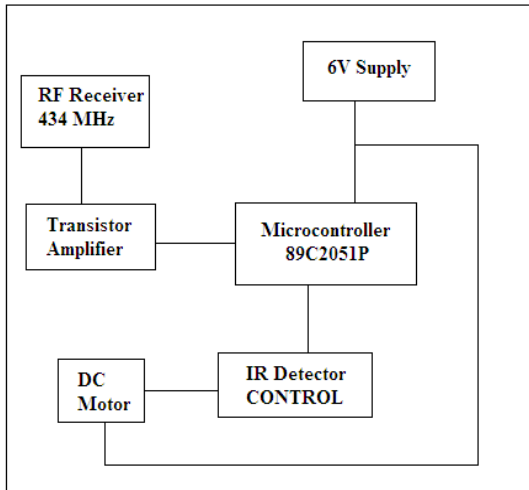

Fig 2. Train Controller [3]

- **STATION CONTROLLER:** It is the centralized unit that controls the entire operation of railway and also the signaling of the system. It also controls the announcements of the trains.

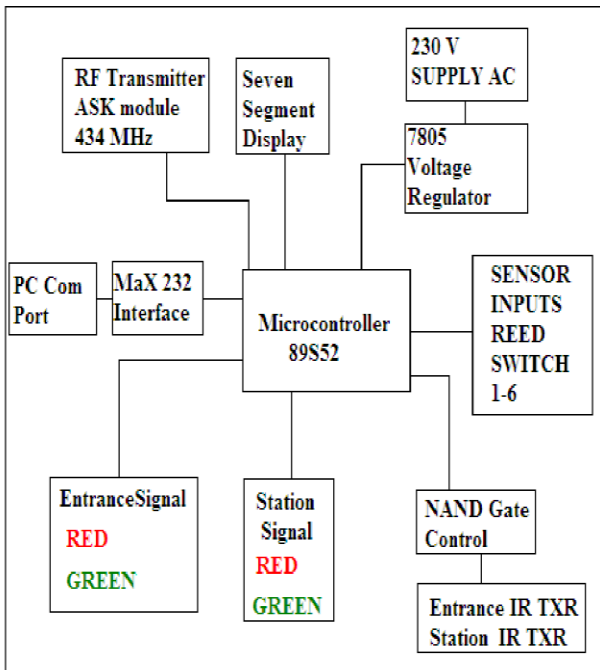

Fig3. STATION CONTROLLER [4]

3. WORKING

The automated driverless railway project basically works on the concept of reed switch, which is actually used for signaling in the railway system. In our project, the reed switches are connected to our micro-controller via a 10k resistor to make it function properly in order to limit the current through the reed switch. Functioning of reed switch is as follows:-

- Normally the contacts of the reed switch are open, when a magnet is moved over the reed switch the contacts of

the reed switch gets short. When the magnet is removed, the contacts again open.

Basic function of the project:-

A main board consists of 89c51 microcontroller. The reed switches are connected on the track which are used to sense the trains. A magnet is connected ahead of each train and also an IR receiver is connected on the train. Also, 89c2051 micro controller is placed on the train, which has IR receiver on it. A signaling pole, which has 2 signals- red and green signal, and a IR transmitter is placed near the reed switch which indicates the signal. Now when a train passes over a particular reed switch, the signaling pole near it comes into the picture. The red signal turns on and green signal goes off. And the IR transmitter is turned on. Now if any train comes behind it, the IR receiver of the next train receives the signal from the IR transmitter and the train stops as per the code. Now, when the train which has gone ahead passes the minimum safe distance which is again sensed by another reed switch, the signal turns green and IR transmitter turns off. As the IR transmitter is off, the IR receiver on the train stops receiving and the stopped train starts moving. This is the working of the whole system where we have placed many. At the station side, the expected in minutes timing is being displayed on the 7-segment displayed. This indicates the 3-2-1 minutes required for the train to come on the platform. Reed switches on the track for minimum safe distance and signal controlling and automated train moving system.

Automatic Block Diagram Using 3-Aspect Signals

Train 1 occupies the first block which is protected by red signal at the entrance. The preceding block does not have a train but a yellow signal gives warning of red aspect ahead of it. This block also provides a safe braking distance for train 2. The block next to it is also clear of trains and gives a green signal. The driver of train 2 thus comes to know that he has two clear blocks ahead of him so he can maintain its desired speed until he sees a yellow signal.

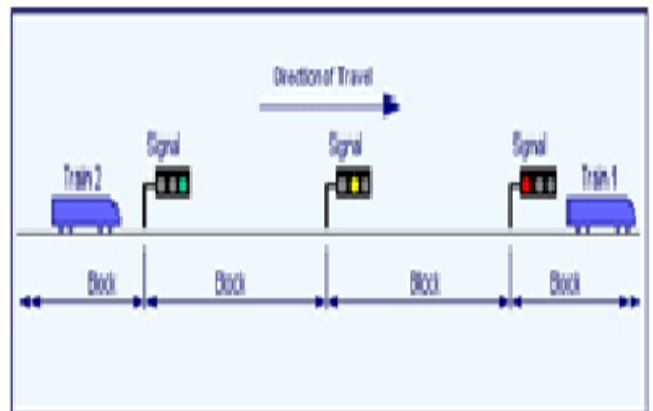

Fig 4. Automatic Block Diagram Using 3-Aspect Signals

4. CONCLUSION

The TMS enables automatic movement of trains and also provides automatic signaling system. It uses the 'fail-safe' system. It also includes interlocking which prevents the system allowing the conflicting and dangerous moves to be made by train. A signal will not allow a train to enter a section which is pre-occupied by another train. The system is highly accurate and efficient.

5. FUTURE SCOPE

Use of wireless medium for communication can bring a revolution in the railway system. Just one person in the control room, controlling the entire railway system, can become a reality in the time to come.

REFERENCES

- i. www.reed-switch.com
- ii. www.railway-technical.com
- iii. www.trainweb.org
- iv. www.trainweb.org