

# De-Noising of Image Using Adaptive Thresholding Technique

Kapil Kapoor<sup>1</sup>, Dr. Abhay Sharma<sup>2</sup>

Research Scholar, Sri Sainath University, Associate Professor, LRIET, Solan  
kapil\_2770@yahoo.com, sharma2abhay1@gmail.com

**Abstract :** This paper describes a computationally more efficient and adaptive threshold estimation method for image de-noising in the wavelet domain based on Generalized Gaussian Distribution (GGD) modelling of sub band coefficients. In this method, the choice of the threshold estimation is carried out by analyzing the statistical parameters of the wavelet sub band coefficients like standard deviation, arithmetic mean and geometrical mean. The noisy image is first decomposed into many levels to obtain different frequency bands. Then soft thresholding method is used to remove the noisy coefficients, by fixing the optimum thresholding value by the proposed method. Experimental results on several test images by using this method show that this method yields significantly superior image quality and better Peak Signal to Noise Ratio (PSNR). Here, in this paper, the role of wavelet based image de-noising by adaptive thresholding technique is discussed.

**Keywords -** Image De-noising, Wavelet Transform, Gaussian Noise, Filter Banks and Thresholding.

**Introduction-** An image is often corrupted by noise in its acquisition and transmission. For example during the image acquisition, the performance of imaging sensors is affected by a variety of factors, such as environmental conditions and by the quality of the sensing elements themselves. For instance, in acquiring images with a CCD camera, light levels and sensor temperature are major factors affecting the amount of noise in the resulting image. Images are also corrupted during transmission, due to interference in the channel used for transmission. Image de-noising techniques are necessary to remove such random additive noises while retaining as much as possible the important signal features. The main objective of these types of random noise removal is to suppress the noise while preserving the original image details. Statistical filters like Average filter [i] [ii], Wiener filter [iii] can be used for removing such noises but the wavelet based de-noising techniques proved better results than these filters. In general, image de-noising imposes a compromise between noise reduction and preserving significant image details. The wavelet representation naturally facilitates the construction of such spatially adaptive algorithms. It compresses essential information in a signal into relatively few, large coefficients, which represent image details at different resolution scales. In recent years there has been a fair amount of research on wavelet thresholding and threshold selection for signal and image de-noising [viii], because wavelet provides an appropriate basis for separate for noisy signal from image signal. Many wavelet based thresholding techniques like VisuShrink [vii], BayesShrink [v] have proved better efficiency in image de-noising. We describe here an efficient thresholding technique for de-noising by analyzing the statistical parameters of the wavelet coefficients.

**DISCRETE WAVELET TRANSFORM-** The DWT is identical to a hierarchical subband system where the subbands are logarithmically spaced in frequency and represent octave-band decomposition. Due to the decomposition of an image using the DWT [x] the original image is transformed into four pieces which is normally labeled as LL, LH, HL and HH as in the schematic depicted in Fig.1 (a). The LL subband can be further decomposed into four subbands labelled as LL2, LH2, HL2 and HH2 as shown in Fig. I (b).

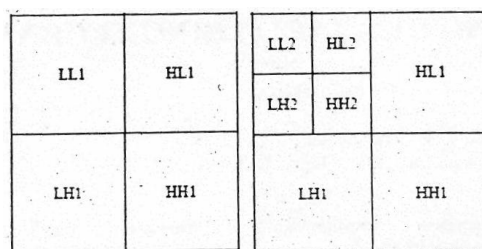

Fig. 1(a) One Level Fig. 1(b) Two Level

Fig. 1 Image decomposition by using DWT

The LL piece comes from low pass filtering in both directions and it is the most like original picture and so is called the approximation. The remaining pieces are called detailed components. The HL comes from low pass filtering in the vertical direction and high pass filtering in the horizontal direction and so has the label HL. The visible detail in the sub-image, such as edges, has an overall vertical orientation since their alignment is perpendicular to the direction, of the high pass filtering and they are called vertical details. The remaining components have analogous explanations. The filters LD and HD shown in Fig. 2 are one-dimensional Low Pass Filter (LPF) and High Pass Filter (HPF) respectively for image decomposition. To obtain the next level of decomposition, sub band LL1 alone is further decomposed. This process continues until some final scale is reached. The decomposed image can be reconstructed using a reconstruction filter as shown in Fig. 3. Here, the filters LR and HR represent low pass and high pass reconstruction filters respectively. Here, since the image size is not changed after decomposition this DWT is called critically sampled transform without having any redundancy.

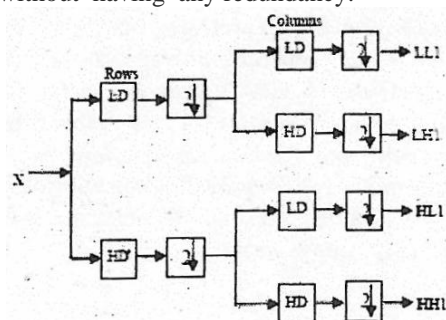
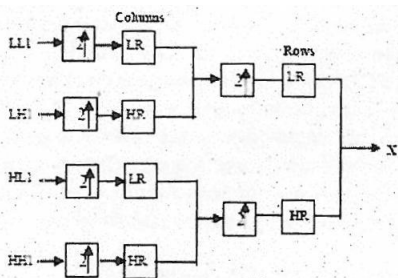

Fig. 2 Wavelet Filter bank for one-level image decomposition



**Fig. 3** Wavelet Filter bank for one-level image reconstruction

**WAVELET THRESHOLDING-** Let  $f = \{f_{ij}, i, j=1, 2, \dots, M\}$  denotes a  $M \times M$  matrix of original image to be recovered and  $M$  is some integer power of 2. During the transmission, the signal  $f$  is corrupted by independent and identically distributed (i.i.d) zero mean, white Gaussian noise  $n_{ij}$  with standard deviation  $\sigma$  i.e.  $n_{ij} \sim N(0, \sigma^2)$  and at the receiver end, the noisy observation  $g_{ij} = f_{ij} + n_{ij}$  is obtained. The goal is to estimate the signal  $f$  from the noisy observations  $g_{ij}$  such that the Mean Square Error (MSE) is minimum. To achieve this the  $g_{ij}$  is transformed into wavelet domain, which decomposes the  $g_{ij}$  into many sub bands as explained in section 2, which separates the signal into so many frequency bands. The small coefficients in the sub-bands are dominated by noise, while coefficients with large absolute value carry more signal information than noise. Replacing noisy coefficients (small coefficients below a certain value) by zero and an inverse wavelet transform may lead to reconstruction that has lesser noise. Normally Hard Thresholding and Soft Thresholding techniques are used for such de-noising process. Hard and Soft thresholding  $[x_i]$  with threshold  $\lambda$  are defined as follows.

The hard thresholding operator is defined as

$$D(U, \lambda) = U \text{ for all } |U| > \lambda$$

$$= 0 \text{ otherwise} \dots\dots (1)$$

The soft thresholding operator on the other hand is defined as

$$D(U, \lambda) = \text{sgn}(U) * \max(0, |U| - \lambda) \dots\dots (2)$$

Hard thresholding is "keep or kill" procedure and is more intuitively appealing and also it introduces artifacts in the recovered images. But Soft thresholding is more efficient and it is used for the entire algorithm for the following reasons: Soft thresholding has been shown to achieve near minmax rate over a large number of Besov spaces [ix]. Moreover, it is also found to yield visually more pleasing images. The above factors motivate us to use this Soft thresholding in this proposed de-noising method.

**ESTIMATION OF PARAMETERS FOR THRESHOLD VALUE-**

Finding an optimum threshold value ( $\lambda$ ) for soft thresholding is not an easy task. A small threshold value will pass all the noisy coefficients and hence the resultant de-noised signal may still be noisy. A large threshold value on the other hand, makes more number of coefficients as zero which leads to smooth signal and destroys details and in image processing may cause blur and artifacts. So, optimum threshold value should be found out, which is adaptive to different subband characteristics. Here, we describe an efficient method for fixing the threshold value for de-noising by analyzing the statistical parameters of the wavelet coefficients. The threshold value ( $T$ ), for soft thresholding technique is

$$T = C \sigma - (AM - GM) \dots\dots (3)$$

Here  $\sigma$  is the noise variance of the corrupted image. In some applications of image de-noising, the value of the input noise variance is known, or can be measured based on the information other than the corrupted data. If this is not the case, one has to estimate it from the input data, eliminating the input

of actual signal. For this, wavelet based method commonly used the highest frequency subband of the decomposition. In the DWT of the image, the HH1 subband contains mainly noise. For estimating the noise level we use the relation proposed by Donoho [1][6], which is denoted as

$$\sigma = \frac{\text{Median}|Y_{ij}|}{0.6745}, Y_{ij} \in \text{subband HH}_1, \dots\dots (4)$$

Normally in wavelet sub bands, as the level increases the coefficients of the subband becomes smoother. For example the subband HL2 is smoother than the corresponding subband in the first level (HL1) and so the threshold value of HL2 should be smaller than that for HL1. The term  $C$  is included for this purpose to make the threshold value as decomposition level dependent which is given as

$$C = 2(L - k) \dots\dots (5)$$

Where,  $L$  is the no. of wavelet decomposition level,  $k$  is the level at which the subband is available (for HL2,  $k=2$ ). The term  $|AM - GM|$  is the absolute value of difference between Arithmetic Mean and Geometric Mean of the subband coefficients. This term is the measure of the smoothness of the image to be de-noised. If an image is having more edges, then the noisy wavelet coefficients of the image should be removed by fixing slightly lower threshold value so as to keep the image edges undisturbed. This can be achieved by this term, since small value of this term indicates that the subband is having smooth edges and vice versa. This term makes the threshold value as image dependent and helps to preserve the image edges to some extent, which results in better image quality. The Arithmetic Mean and Geometric Mean of the subband matrix  $X(ij)$  are denoted as,

$$\text{Arithmetic Mean (AM)} = \frac{1}{M^2} \sum_{i=1}^M \sum_{j=1}^M X(ij) \dots\dots (6)$$

$$\text{Geometric Mean (GM)} = \left[ \prod_{i=1}^M \prod_{j=1}^M X(ij) \right]^{\frac{1}{M^2}} \dots\dots (7)$$

Thus each term in equation (3) has its own importance as explained above to make the threshold value more adaptive to sub-band coefficients as well as level of decomposition.

**IMAGE DE-NOISING ALGORITHM** - The Complete algorithm of proposed wavelet based de-noising technique is explained in the following steps.

- Perform the DWT of the noisy image up to 2 levels ( $L=2$ ) to obtain seven sub bands which are named as HH1, LH1, HL1, HH2, LH2, HL2 and LL2.
- Compute the threshold value for each subband, except the LL2 band using equation (3), after finding out its following terms.
  - a) Obtain the noise variance using the equation (4).
  - b) Find the term  $C$  for each subband using the relation given in equation (5).
  - c) Calculate the term  $|AM - GM|$  using the equations (6) and (7).
- Threshold the all subband coefficients (except LL2) using Soft Thresholding technique given in equation (2), by substituting the threshold value obtained in the step 2.
- Perform the inverse DWT to reconstruct the de-noised image.

**EXPERIMENTAL RESULTS AND DISCUSSION-** The above algorithm has been applied on several natural gray scale test images like Lena, Barbara and Seed of size

512 x 512, at different Gaussian noise of levels: (Standard Deviation)  $\sigma = 1, 5, 20, 25, 30, 35$ . Here, we used 'Daubechies' (Db4) [xii], the least asymmetric compactly supported wavelet at two levels of decomposition. To evaluate the performance of the proposed method, it is compared with BayesShrink VisuShrink, average filter and wiener filter using Peak Signal to Noise Ratio (PSNR) [xiii], which is defined as

$$PSNR = 10 \log_{10} \left[ \frac{255^2}{MSE} \right] \text{dB} \dots\dots (8)$$

Where, MSE denotes the Mean Square Error between the original and de-noised images, and is given as

$$MSE = \frac{1}{MN} \sum_{i=1}^M \sum_{j=1}^N [X(i, j) - P(i, j)]^2 \dots\dots (9)$$

Where,

- M - Width of image
- N - Height of Image
- P - Noisy Image or processed Image
- X - Original Image

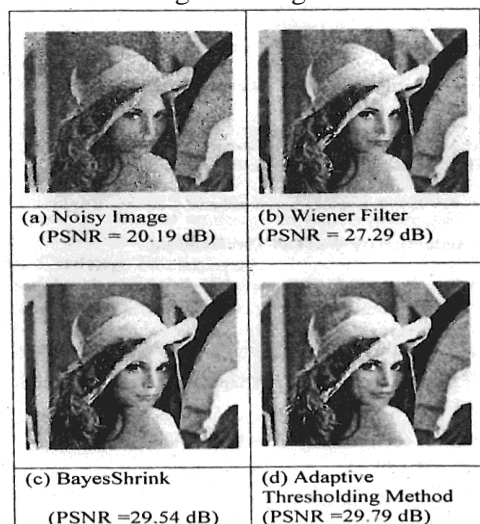

**Fig. 4** De-noising of 'Lena' image corrupted by Gaussian Noise of standard Deviation of 25

**CONCLUSION** - Since the adaptive thresholding method is based on the analysis of statistical parameters like arithmetic mean, geometrical mean and standard deviation of the subband coefficients, it is more subband adaptive. Experiments conducted on different natural images corrupted by various noise levels to access the performance of proposed thresholding method in comparison with VisuShrink, BayesShrink and filters like wiener and average filters show that this method gives

better results. Since the de-noising of images which is effected through the proposed thresholding technique has possessed better PSNR, this method finds its application in de-noising images those are corrupted during transmission, which is normally random in nature.

**REFERENCES:**

- i. Maher A. Sid-Ahmed. (1995), *Image Processing-Theory algorithm and architecture.*
- ii. Rafael C. Gonzalez & Richard E. Wodds (1993), *Digital Image Processing, Addison Wesley Publishing Co.*
- iii. Javier Portilla, Vasily Strela, Martin J. Wainwright and Eero P. Simoncelli (2002), *Adaptive Wiener Denoising using a Gaussian Scale Mixture Model in the wavelet Domain*
- iv. Maarten Janse (2001), *Noise Reduction by Wavelet Thresholding.*
- v. S. Grace Chang, Bin Yu and M. Vattereli (2000), *Adaptive Wavelet Thresholding for Image denoising and Compression. IEEE Transaction on Image Processing.*
- vi. D.L. Donoho and I.M. Johnstone (1995), *Adapting to unknown smoothness via wavelet shrinkage.*
- vii. D.L. Donoho (1994), *Ideal spatial adoption by wavelet shrinkage*
- viii. S. Grace Chang, Bin Yu and M. Vattereli (2000), *Spatially Adaptive Wavelet Thresholding with Context Modeling for Imaged noising. IEEE Transaction on Image Processing.*
- ix. M. Vattereli and J. Kovacevic (1995), *Wavelets and Subband Coding. Englewood Cliffs, NJ, Prentice Hall.*
- x. Raghuvveer M. Rao and Ajit. S. Bopardikar. (1998), *Wavelet Transforms: Introduction to theory and applications''. Addison Wesley Longman Inc.*
- xi. D.L. Donoho (1995), *De-noising by soft thresholding. IEEE Transactions on Information Theory*
- xii. I. Daubechies (1992), *Ten Lectures on Wavelets. Philadelphia SIAM.*
- xiii. Amir Said. ( 1995). *A New and Efficient Image Codec Based On Set Partitioning in sHierarchical Tress, I EEE Transaction on circuit and system for video technology.*
- xiv. *A Survey of Digital Watermarking Techniques and its Applications, Lalit Kumar Saini, Vishal Shrivastava, IJCST) – Volume 2 Issue 3, May-Jun 2014*
- xv. *DIGITAL IMAGE WATERMARKING ALGORITHMS BASED ON DUAL TRANSFORM DOMAIN AND SELF-RECOVERY, Zhu Yuefeng , Lin Li,IJSSIS, March2015*
- xvi. *Comparison of Digital Image watermarking Methods DWT & DWT-DCT on the Basis of PSNR , Navnidhi Chaturvedi, Dr.S.J.Basha , IJIRSET, Vol. 1, Issue 2, December 2012*
- xvii. *Comparative Analysis of Watermarking in Digital Image using DCT & DWT, Radhika v. Totla, K.S.Bapat ,IJSR, Volume 3, Issue 2, February 2013*