

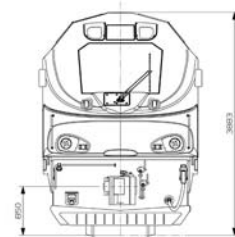

ASIALight

Diesel-Electric Locomotive

For passenger and freight applications

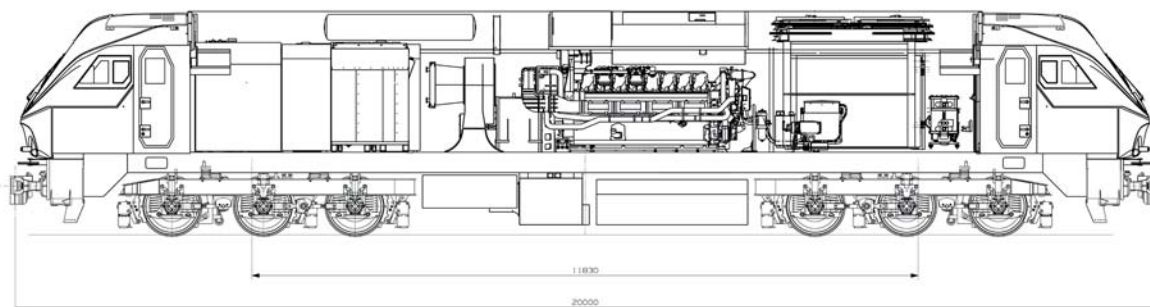

GENERAL CHARACTERISTICS

Axle arrangement	Co'Co'
Gauge	1,000 mm – 1,067 mm
Weight	96 tons
Axle load	16 tons
Maximum speed	120 km/h
Starting tractive effort	320 kN
Number of cabs	2, air-conditioned
Fuel tank	4,000 l
Multiple unit	Yes (2 units)
HEP Inverter	Up to 500 kW
Noise	TSI CR Noise 01/06-ST05
Exhaust emissions	EU 97/68 Stage IIIA

DIESEL ENGINE

Manufacturer	CAT / MTU / Cummins
Power	2,800 KW / 1,800 – 2,000 KW
Number of cylinders	16V – 12V
Rated speed	1,800 rpm

BRAKE SYSTEM

Pneumatic	UIC Electropneum.
Dynamic Brake	Yes
Blending Features	Opt.
Wheel slide protection	Yes

ELECTRICAL TRANSMISSION

Type	AC/AC
Supplier	ABB
Traction Motors	6 units
Power Train supply	HEP Inverter

BOGIE

Bogie Frame	Fabricated Steel
Wheel	1,016 mm, R8T
Suspensions:	-Primary: Coil Springs -Secondary: rubber-metal -Vertical, horizontal dampers
Traction Motor	Nose suspended
Brake	Brake Shoes

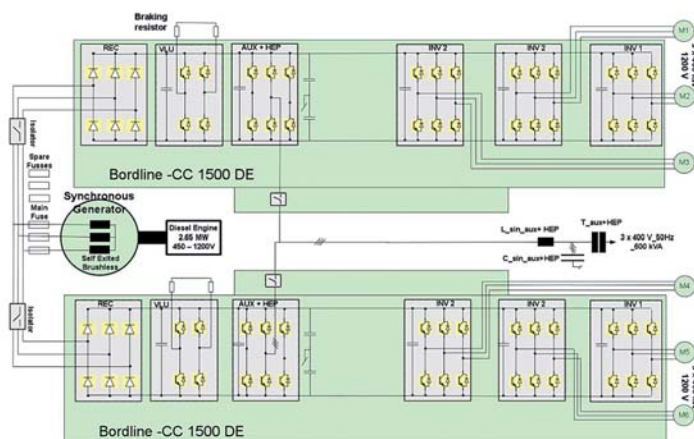

Vossloh Rail Vehicles S.A.
 Poligono Industrial del Mediterraneo
 C. Mitjera, n.6
 46550 Albuixech (Valencia)
 ESPAÑA
 Tel.: +34.96.1415000
 Fax: +34.96.1415007
www.vossloh-rail-vehicles.com