

2012 magazine specifications



REPORT ON BUSINESS

MAGAZINE

*STANDARD FORMATS APPLY TO REPORT ON BUSINESS MAGAZINE AND CANADIAN UNIVERSITY REPORT

*ADVANCED FORMATS APPLY TO REPORT ON BUSINESS MAGAZINE ONLY

SPECIFICATIONS SUBJECT TO CHANGE VISIT OUR WEBSITE FOR UPDATES

FOR FURTHER ADVERTISING INFORMATION PLEASE VISIT GLOBELINK.CA

UPDATED JANUARY 2012

advertising formats standard



FULL PAGE

LIVE: 7" w x 10" d
TRIM: 7 7/8" w x 10 3/4" d
BLEED: 8 1/8" w x 11" d



INSIDE BACK COVER

LIVE: 7" w x 10" d
TRIM: 7 7/8" w x 10 3/4" d
BLEED: 8 1/8" w x 11" d



OUTSIDE BACK COVER

LIVE: 7" w x 10" d
TRIM: 7 7/8" w x 10 3/4" d
BLEED: 8 1/8" w x 11" d

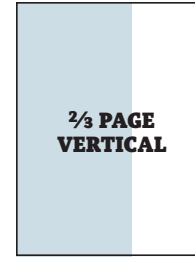

2/3 PAGE VERTICAL

LIVE: 4 3/8" w x 10" d
TRIM: 4 5/8" w x 10 3/4" d
BLEED: 4 7/8" w x 11" d

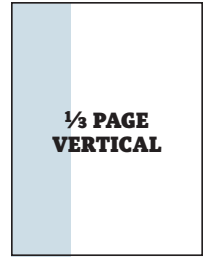

1/3 PAGE VERTICAL

LIVE: 2" w x 10" d
TRIM: 2 1/4" w x 10 3/4" d
BLEED: 2 1/2" w x 11" d

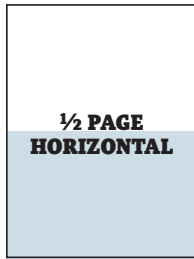

1/2 PAGE HORIZONTAL

LIVE: 7" w x 4 15/16" d
TRIM: 7 7/8" w x 5 3/8" d
BLEED: 8 1/8" w x 5 5/8" d

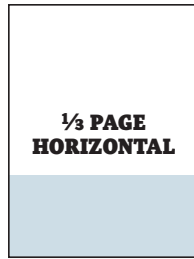

1/3 PAGE HORIZONTAL

LIVE: 7" w x 3 1/8" d
TRIM: 7 7/8" w x 3 3/8" d
BLEED: 8 1/8" w x 3 5/8" d

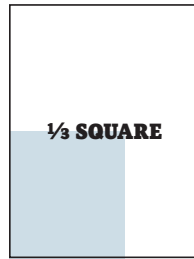

1/3 SQUARE

LIVE: 4 3/8" w x 4 15/16" d
TRIM: 4 5/8" w x 5 3/8" d
BLEED: 4 7/8" w x 5 5/8" d

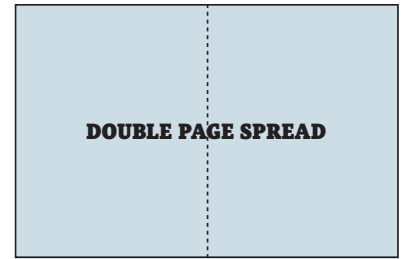

DOUBLE PAGE SPREAD

LIVE: 14" w x 10" d
TRIM: 15 3/4" w x 10 3/4" d
BLEED: 16 1/4" w x 11" d

*MUST BUILD AS TWO SEPERATE PAGES

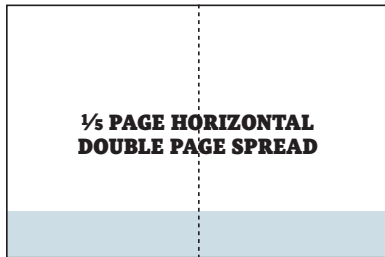

1/5 PAGE HORIZONTAL DOUBLE PAGE SPREAD

LIVE: 14" w x 1 5/8" d
TRIM: 15 3/4" w x 2" d
BLEED: 16 1/4" w x 2 1/4" d

*MUST BUILD AS TWO SEPERATE PAGES

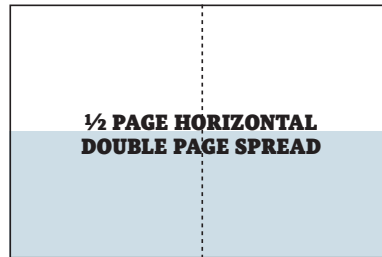

1/2 PAGE HORIZONTAL DOUBLE PAGE SPREAD

LIVE: 14" w x 4 15/16" d
TRIM: 15 3/4" w x 5 3/8" d
BLEED: 16 1/4" w x 5 5/8" d

*MUST BUILD AS TWO SEPERATE PAGES

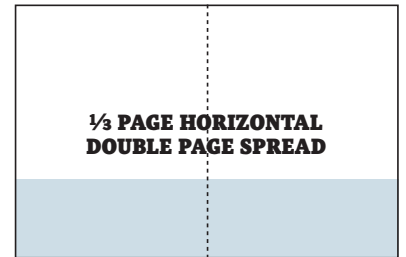

1/3 PAGE HORIZONTAL DOUBLE PAGE SPREAD

LIVE: 14" w x 3 1/8" d
TRIM: 15 3/4" w x 3 3/8" d
BLEED: 16 1/4" w x 3 5/8" d

*MUST BUILD AS TWO SEPERATE PAGES

advanced formats

1/3 HORIZONTAL

LIVE: 7" w x 3 1/8" d
TRIM: 7 7/8" w x 3 3/8" d
BLEED: 8 1/8" w x 3 5/8" d

1/3 VERTICAL

LIVE: 2" w x 10" d
TRIM: 2 1/4" w x 10 3/4" d
BLEED: 2 1/2" w x 11" d

REVERSE L

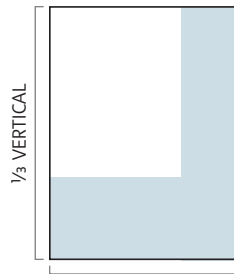

1/3 VERTICAL

1/3 HORIZONTAL

RACETRACK

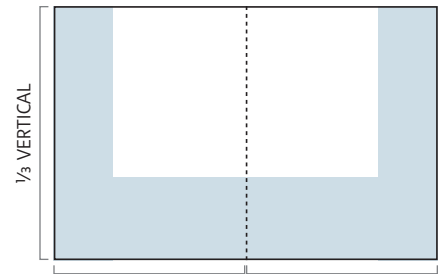

1/3 VERTICAL

1/3 HORIZONTAL

1/3 HORIZONTAL

*SPECIAL FORMATS APPLY TO REPORT ON BUSINESS MAGAZINE ONLY

advertising formats
special

GATEFOLD • INSIDE FRONT COVER

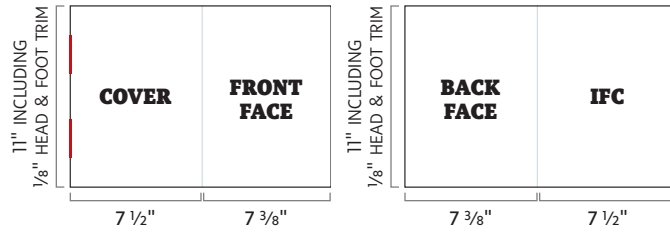

6 PAGES LEFT HAND, IF CENTER TO THE MAGAZINE
1 x 4 PAGE GATEFOLD IN LOW FOLIO IF BETWEEN 2 SECTIONS

GATEFOLD • 1/3 COVER

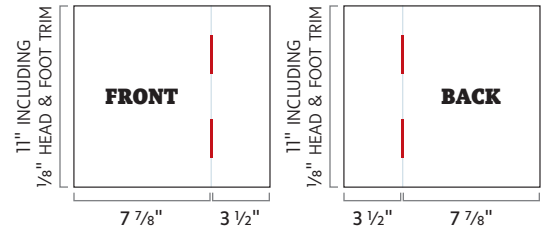

AD WRAPS AROUND COVER

GATEFOLD • 2/3

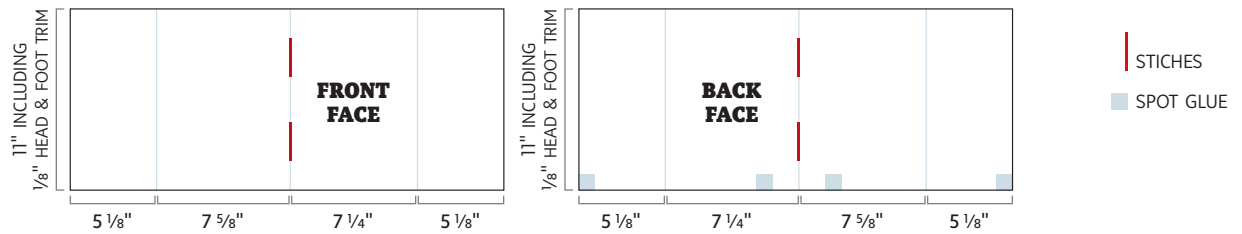

GATEFOLD • 4 PAGE

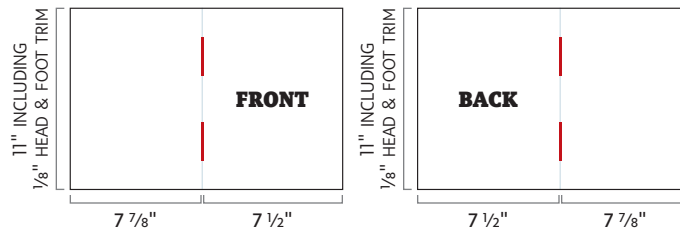

4 PAGES GATEFOLD, IF CENTER TO THE MAGAZINE
2 x 2 PAGES IF BETWEEN 2 SECTIONS

GATEFOLD • 1/3 PAGE

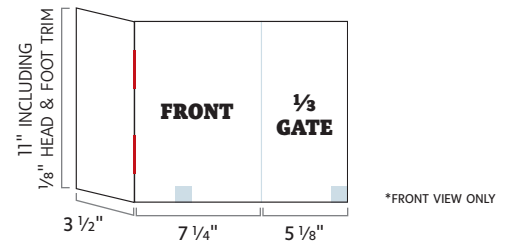

GATEFOLD • 6 PAGE

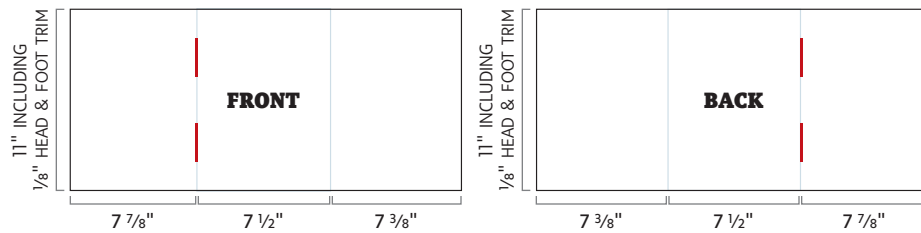

6 PAGES LEFT HAND, IF CENTER TO THE MAGAZINE
1 x 4 PAGE GATEFOLD IN LOW FOLIO IF BETWEEN 2 SECTIONS

GATEFOLD • 8 PAGE

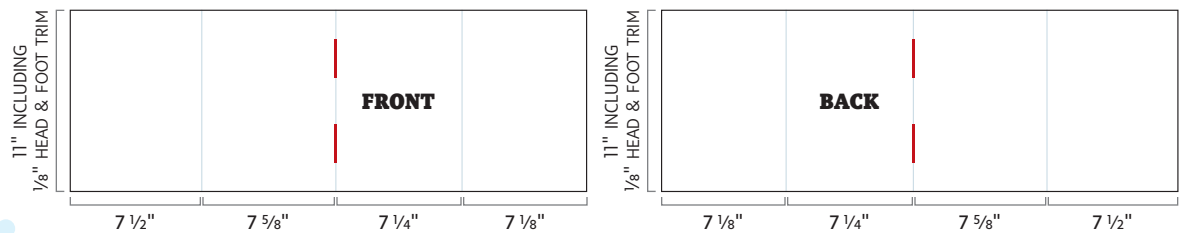

8 PAGES LEFT HAND, IF CENTER TO THE MAGAZINE
2 x 4 PAGE GATEFOLD IF BETWEEN 2 SECTIONS



advertising formats
creative executions



REVERSE L



RACETRACK



DOUBLE 1/3 BANNER



DOUBLE 1/3 BANNER



CANDLESTICKS



MASTHEAD BOOKENDS



MASTHEAD DPS



CONSECUTIVE 1/3 BANNERS



CONSECUTIVE 1/3 VERTICAL



CONSECUTIVE BUILD



specifications & general
requirements

General

- DPS ads must be set up as single pages
- All disks (CD or DVD) must be supplied with a digital halftone proof (eg. Polaproof, Kodak Approval)
- Laser proofs and colour keys are not acceptable proofs
- **Electronically sent material not accepted**
- **All display ads must be sent to: Report on Business magazine
444 Front Street West
Toronto ON M5V 2S9**

General Requirements for Mac

- QuarkXpress 7.0 and up to InDesign CS5 Files
- All high-resolution files in CMYK (minimum 300 dpi)
- All TIFFS and EPS files must be placed in your document
- Adobe Illustrator files must be saved with a preview and all placed art or images must be included
- All screen and printer fonts used in the document (plus all EPS files) must be supplied
- All colours must be defined as CMYK with separation turned on in the edit colours dialog box
- Ads with drop shadows should be layered in offset text boxes
- Crop marks should be offset
- Include a printout of the directory list of all files, fonts, EPS files, etc.

General Requirements for PDF Files

- Optimized PDF_x1a with thumbnail preview
- Output resolution set to 2400 dpi
- No compression or resampling
- Embed all fonts
- Crop marks should be offset
- All embedded art or images should be high resolution in CMYK (minimum 300 dpi)
- No colour conversion and all colours should be defined as CMYK

Mechanical Specifications

- Web offset printing
- 133 Line Screen
- Saddle Stitched
- *Double page spreads: Any headline text crossing the gutter must stay clear of the fold by 1/4" on both pages (total 1/2" between words or characters)

Positioning

- 15% on earned space rates
- Covers are non-cancelable

For More Information

If you require any further information please contact your Globe and Mail advertising representative or:

Liz Massicotte at 416-585-5484 or by email at lmassicotte@globeandmail.com or visit globelink.ca/magazines



advertising formats
inserts

SCENT STRIP

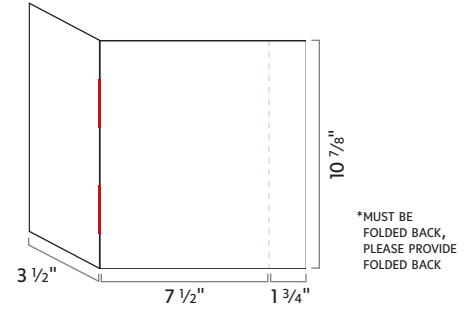
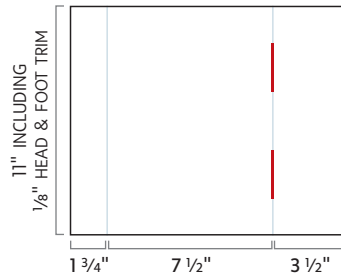
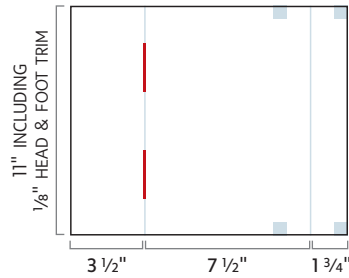

BUSINESS REPLY CARD

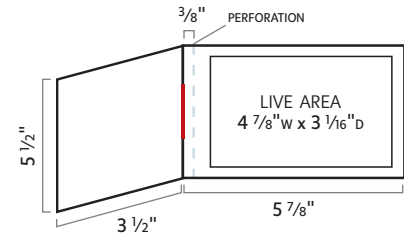
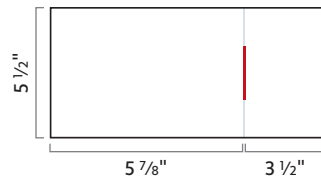
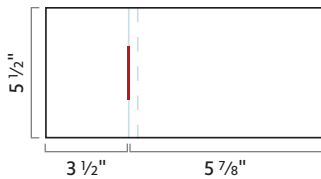

SINGLE-PAGE STITCHED-IN INSERT

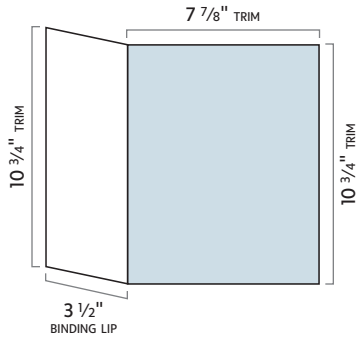

MULTI-PAGE STITCHED-IN INSERT

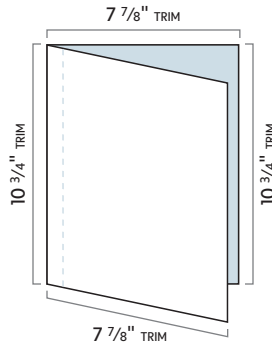

TIP-IN INSERT

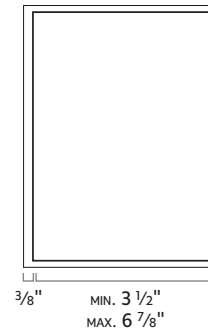

STICHES
SPOT GLUE

LOW FOLIO FRONT TO CENTER: 1/8" BLEED
HIGH FOLIO CENTER TO BACK: 1/8" BLEED + 3/8" LIP
*MULTI-PAGE: MUST BE PRESTITCHED OR UNTRIMMED FORM

Packaging and receiving criteria for inserts supplied by the client

- Inserts can be supplied either directly by the client or by the client's supplier
- A minimum of 2% must be added to the quantity for spoilage
- Inserts must be delivered in good quality, uniform boxes, weighing a maximum of 35lbs, in a manner that keeps them from moving around
- Boxes must be delivered on good quality standard size skids
- 25 samples of each insert must be supplied to Report on Business magazine to:

Isabelle Oandasan
444 Front Street West
Toronto ON M5V 2S9

The following information must appear on the delivery slip

- Client's name
- Item or description of the content
- Name of the magazine to be inserted into
- Issue date
- Quantity per box and total quantity
- **The information above must appear on each box**

Insert Shipping Address

Transcontinental Printing, Imprimerie Interweb Inc.
1603 Montarville Blvd., Shipping & Receiving, Door 10
Boucherville QC J4B 5Y2
tel: 450-655-2801 fax: 450-655-0765
Monday to Friday 8AM to 5PM excluding holidays



REPORT ON
SMALL BUSINESS
 THE GLOBE AND MAIL

<http://www.globelink.ca/magazines>

SPECIFICATIONS SUBJECT TO CHANGE VISIT OUR WEBSITE FOR UPDATES

FOR FURTHER ADVERTISING INFORMATION PLEASE VISIT GLOBELINK.CA

UPDATED JANUARY 2012

*TABLOID FORMATS APPLY TO REPORT ON SMALL BUSINESS MAGAZINE ONLY

advertising formats
tabloid



FULL PAGE
 LIVE: 236mm w x 251mm d
 9.29"w x 9.88"d



INSIDE BACK COVER
 LIVE: 236mm w x 251mm d
 9.29"w x 9.88"d

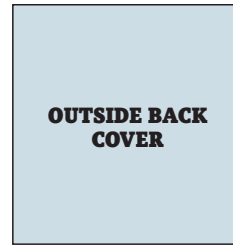

OUTSIDE BACK COVER
 LIVE: 236mm w x 251mm d
 9.29"w x 9.88"d

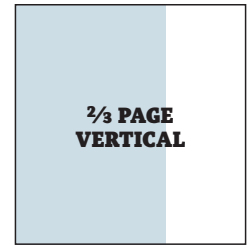

2/3 PAGE VERTICAL
 LIVE: 156mm w x 251mm d
 6.14"w x 9.88"d

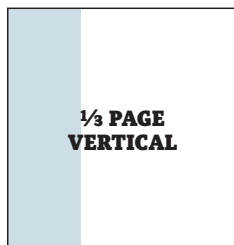

1/3 PAGE VERTICAL
 LIVE: 76mm w x 251mm d
 2.99"w x 9.88"d

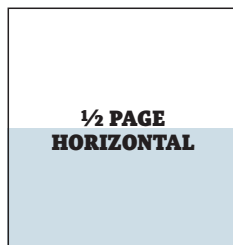

1/2 PAGE HORIZONTAL
 LIVE: 236mm w x 125mm d
 9.29"w x 4.92"d

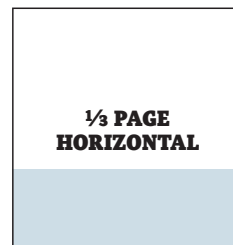

1/3 PAGE HORIZONTAL
 LIVE: 236mm w x 82mm d
 9.29"w x 3.22"d

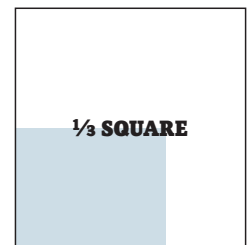

1/3 SQUARE
 LIVE: 156mm w x 125mm d
 6.14"w x 4.92"d

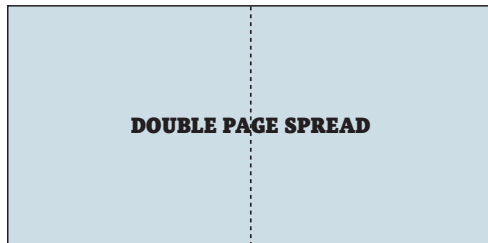

DOUBLE PAGE SPREAD
 LIVE: 498mm w x 251mm d
 19.57"w x 9.88"d

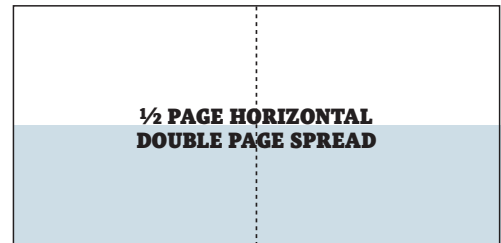

1/2 PAGE HORIZONTAL DOUBLE PAGE SPREAD
 LIVE: 498mm w x 125mm d
 19.57"w x 4.92"d

DOUBLE PAGE SPREAD RUNS ACROSS GUTTER, ONLY AVAILABLE IN CENTER SPREAD

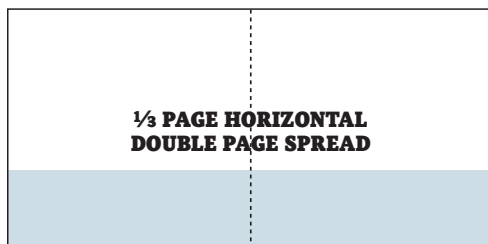

1/3 PAGE HORIZONTAL DOUBLE PAGE SPREAD
 LIVE: 498mm w x 82mm d
 19.57"w x 3.22"d

DOUBLE PAGE SPREAD RUNS ACROSS GUTTER,
 ONLY AVAILABLE IN CENTER SPREAD

*AD SIZES ARE PRINTABLE AREA ONLY, WE CANNOT ACCEPT BLEED ADS



REPORT ON
SMALL BUSINESS
THE GLOBE AND MAIL

*REQUIREMENTS FOR REPORT ON SMALL BUSINESS MAGAZINE

<http://www.globelink.ca/magazines>

SPECIFICATIONS SUBJECT TO CHANGE VISIT OUR WEBSITE FOR UPDATES

FOR FURTHER ADVERTISING INFORMATION PLEASE VISIT GLOBELINK.CA

UPDATED JANUARY 2012

specifications & requirements
tabloid

General

- Ads must be created at 100% final booked size
- Ad material not sent in at final size may be floated within the ad space or scaled to fit
- The given ad size is the final trim size, there is no bleed allowance
- No trapping, chokes or spreads should be used
- DPS ads must be set up as single pages
- **All display ads must be sent to: Report on Business magazine
444 Front Street West
Toronto ON M5V 2S9**

General Requirements

- Ad material should be created in a page layout (ie. Adobe InDesign or QuarkXPress) or design (ie. Adobe Illustrator) program
- All high-resolution files in CMYK (minimum 266 dpi)
- All TIFFS and EPS files must be placed in your document
- Adobe Illustrator files must be saved with a preview and all placed art or images must be included
- All screen and printer fonts used in the document (plus all EPS files) must be supplied (do not use artificial type styles)
- All colours must be defined as CMYK with separation turned on in the edit colours dialog box
- Maximum total ink coverage: 240%
- Midtone dot gain: 26%
- Minimum line thickness: 0.5pt

General Requirements for PDF Files

- Optimized PDF_x1a with thumbnail preview
- Output resolution set to 2400 dpi
- No compression or resampling
- Embed all fonts
- All embedded art or images should be high resolution in CMYK (minimum 266 dpi)
- No colour conversion and all colours should be defined as CMYK

Mechanical Specifications

- Web offset printing
- 133 Line Screen
- Saddle Stitched
- *Double page spreads: Any headline text crossing the gutter must stay clear of the fold by ¼" on both pages (total ½" between words or characters)

Positioning

- 15% on earned space rates
- Covers are non-cancelable

For More Information

If you require any further information please contact your Globe and Mail advertising representative or:

Liz Massicotte at 416-585-5484 or by email at lmassicotte@globeandmail.com or visit globelink.ca/magazines

